



TMG130N12HP

N-Channel Enhancement Mosfet

<p>General Description</p> <ul style="list-style-type: none"> • Low $R_{DS(ON)}$ • RoHS and Halogen-Free Compliant <p>Applications</p> <ul style="list-style-type: none"> • Load switch • PWM 	<p>General Features</p> <p>$V_{DS} = 120V$ $I_D = 130A$ $R_{DS(ON)} = 6.0m\Omega$ (typ.) @ $V_{GS} = 10V$</p> <p>100% UIS Tested 100% R_g Tested</p> 
--	--

P:TO-220AB

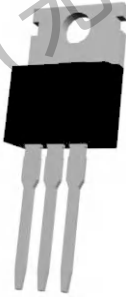
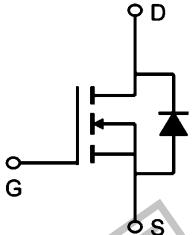
Marking: G130N12H

G D S

Absolute Maximum Ratings ($T_c = 25^\circ C$ unless otherwise noted)

Symbol	Parameter	Value	Units
V_{DSS}	Drain-to-Source Voltage	120	V
I_D	Continuous Drain Current	$T_c = 25^\circ C$	130
	Continuous Drain Current	$T_c = 100^\circ C$	85
I_{DM}^{a1}	Pulsed Drain Current	461	A
E_{AS}^{a2}	Single pulse avalanche energy	326	mJ
V_{GS}	Gate-to-Source Voltage	± 20	V
P_D	Power Dissipation	119	W
T_J, T_{STG}	Operating Junction and Storage Temperature Range	175, -55 to 175	$^\circ C$
T_L	Maximum Temperature for Soldering	260	$^\circ C$

Thermal Characteristics

Symbol	Parameter	Value	Units
$R_{\theta JC}$	Thermal Resistance, Junction-to-Case	1.05	$^\circ C/W$
$R_{\theta JA}$	Thermal Resistance, Junction-to-Ambient	52	$^\circ C/W$

TMG130N12HP

N-Channel Enhancement Mosfet

Electrical Characteristics (Tc= 25°C unless otherwise specified) :

Static Characteristics						
Symbol	Parameter	Test Conditions	Value			Units
			Min.	Typ.	Max.	
V _{DSS}	Drain to Source Breakdown Voltage	V _{GS} =0V, I _D =250μA	120	--	--	V
I _{DSS}	Drain to Source Leakage Current	V _{DS} = 120V, V _{GS} = 0V	--	--	1	μA
I _{GSS(F)}	Gate to Source Forward Leakage	V _{GS} =+20V	--	--	100	nA
I _{GSS(R)}	Gate to Source Reverse Leakage	V _{GS} =-20V	--	--	-100	nA
V _{GS(TH)}	Gate Threshold Voltage	V _{DS} =V _{GS} , I _D = 250μA	3.0	4.0	5.0	V
R _{DS(ON)}	Drain-to-Source On-Resistance	V _{GS} =10V, I _D =20A	--	6	7.5	mΩ
Dynamic Characteristics						
Symbol	Parameter	Test Conditions	Value			Units
			Min.	Typ.	Max.	
C _{iss}	Input Capacitance	V _{GS} = 0V V _{DS} = 60V f = 1.0MHz	--	3614	--	pF
C _{oss}	Output Capacitance		--	423	--	
C _{rss}	Reverse Transfer Capacitance		--	12	--	
R _g	Gate resistance		--	0.84	--	Ω
Resistive Switching Characteristics						
Symbol	Parameter	Test Conditions	Value			Units
			Min.	Typ.	Max.	
t _{d(ON)}	Turn-on Delay Time	I _D =20A	--	20	--	ns
t _r	Rise Time	V _{DS} = 60V	--	65	--	
t _{d(OFF)}	Turn-Off Delay Time	V _{GS} = 10V	--	32	--	
t _f	Fall Time	R _G = 5Ω	--	49	--	
Q _g	Total Gate Charge	V _{GS} =0~10V	--	60.8	--	nC
Q _{gs}	Gate Source Charge	V _{DS} = 60V	--	18.8	--	
Q _{gd}	Gate Drain Charge	I _D =20A	--	14.7	--	
Source-Drain Diode Characteristics						
Symbol	Parameter	Test Conditions	Value			Units
			Min.	Typ.	Max.	
I _S	Diode Forward Current	T _C =25 °C	--	--	130	A
V _{SD}	Diode Forward Voltage	I _S =20A, V _{GS} =0V	--	0.83	1.2	V
t _{rr}	Reverse Recovery time	I _S =40A,	--	60	--	ns
Q _{rr}	Reverse Recovery Charge	dI/dt=100A/μs	--	109	--	nC

a¹: Repetitive rating; pulse width limited by maximum junction temperature

a²: VDD=60V, L=0.5mH, Rg=25Ω, Starting T_J=25 °C

TMG130N12HP

N-Channel Enhancement Mosfet

Characteristics Curve:

Typ. output characteristics
 $I_D=f(V_{DS})$

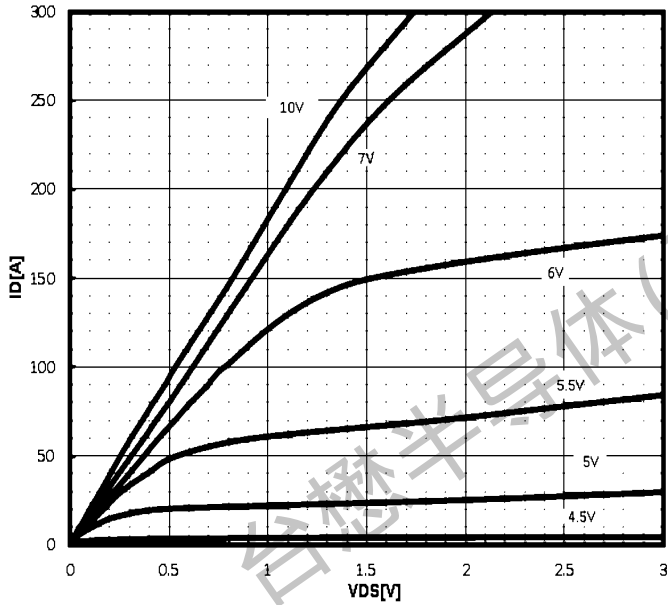

Typ. drain-source on resistance
 $R_{DS(on)}=f(I_D)$

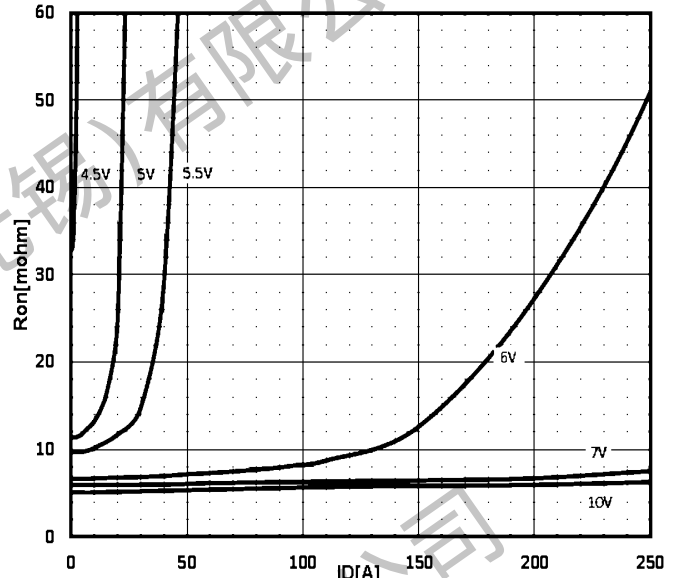

Typ. transfer characteristics
 $I_D=f(V_{GS})$

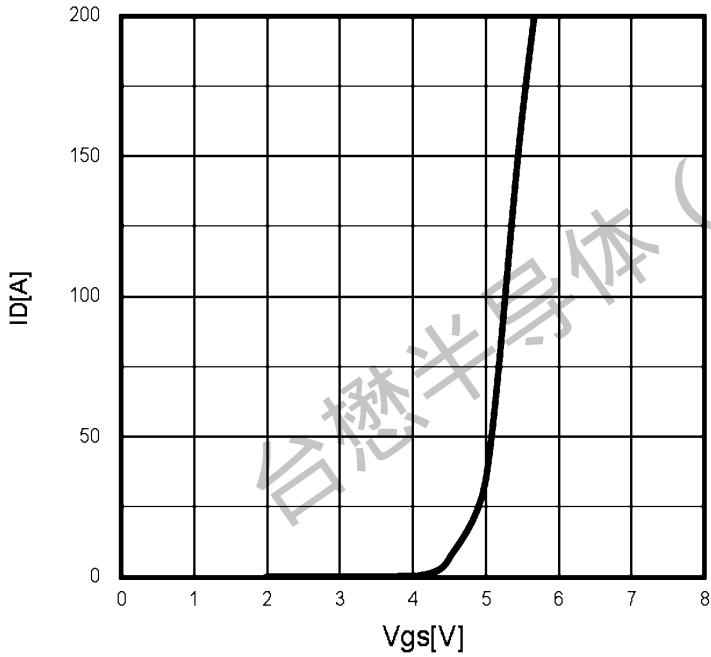

Drain-source on-state resistance
 $R_{DS(on)}=f(T_j); I_D=20A; V_{GS}=10V$

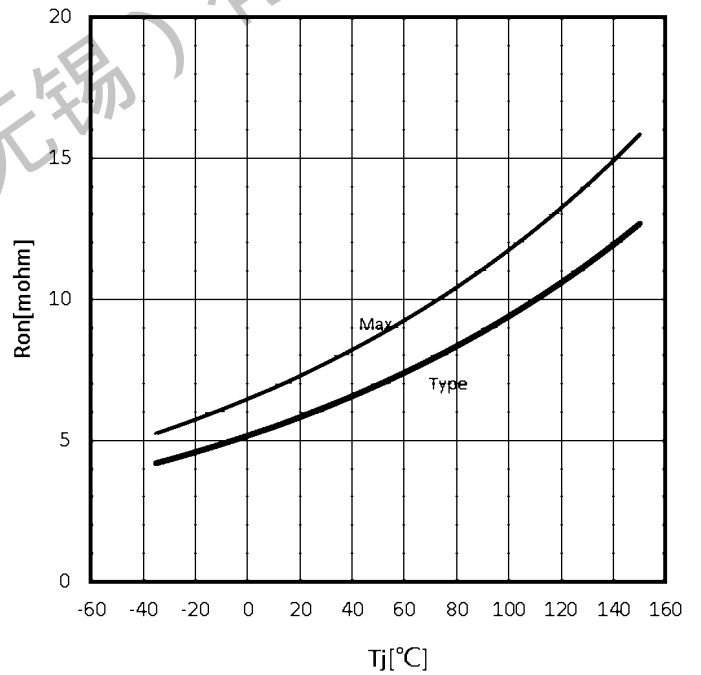



TMG130N12HP

N-Channel Enhancement Mosfet

Gate Threshold Voltage

$V_{TH}=f(T_j); I_D=250\mu A$

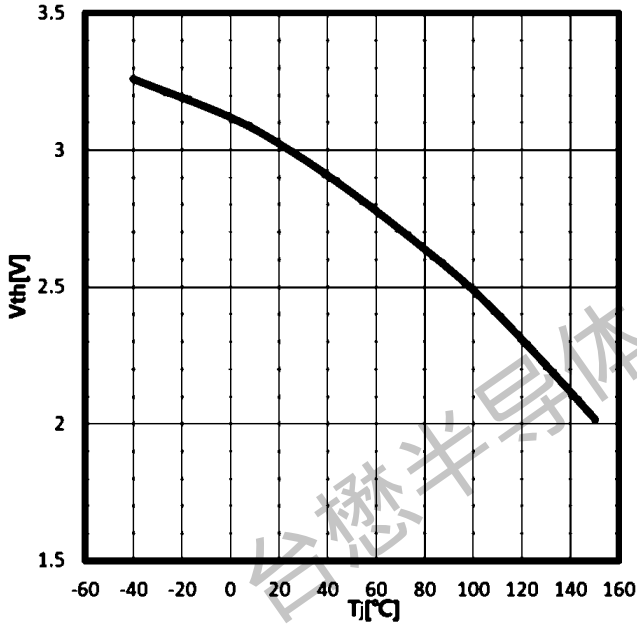

Drain-source breakdown voltage

$V_{BR(DSS)}=f(T_j); I_D=250\mu A$

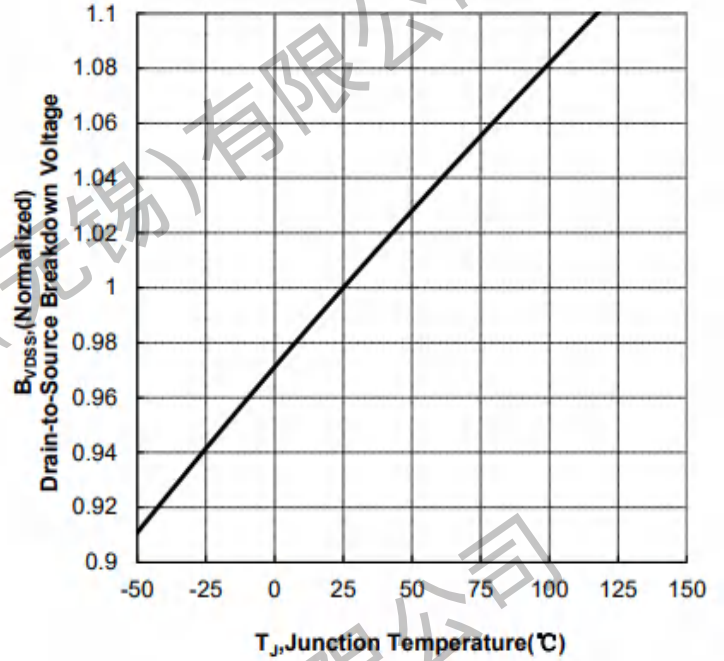

Typ. gate charge

$V_{GS}=f(Q_{gate})$

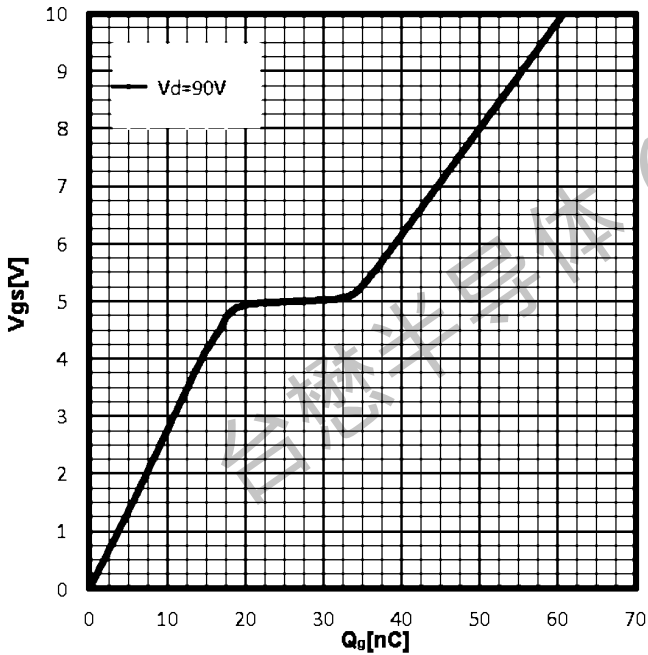

Typ. capacitances

$C=f(V_{DS}); V_{GS}=0V; f=1MHz$

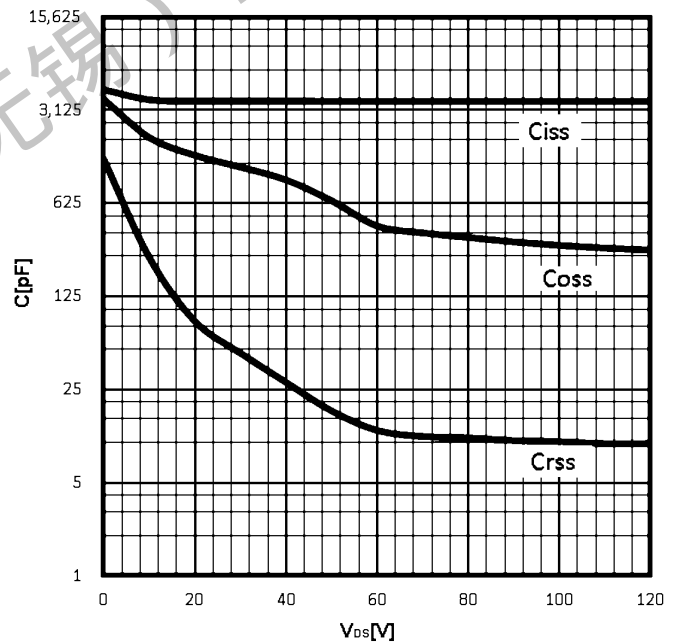



TMG130N12HP

N-Channel Enhancement Mosfet

Power Dissipation
 $P_{tot}=f(T_j)$

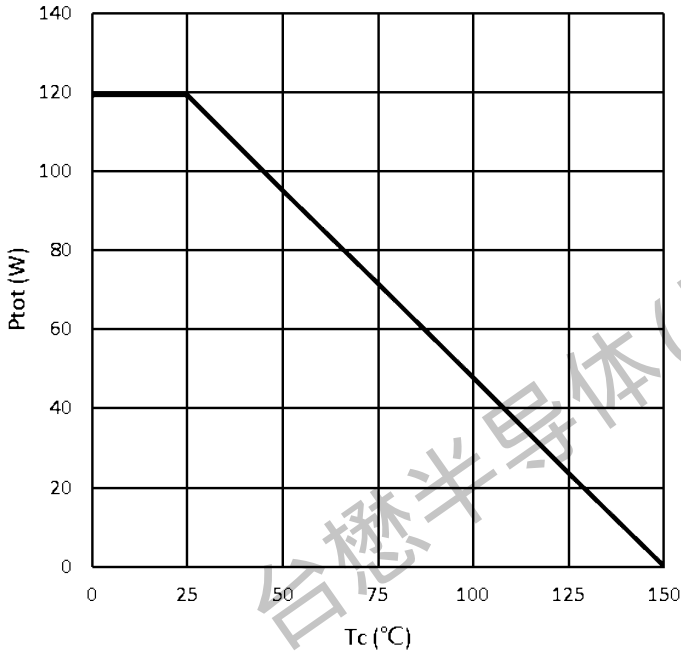

Maximum Drain Current
 $I_D=f(T_c)$

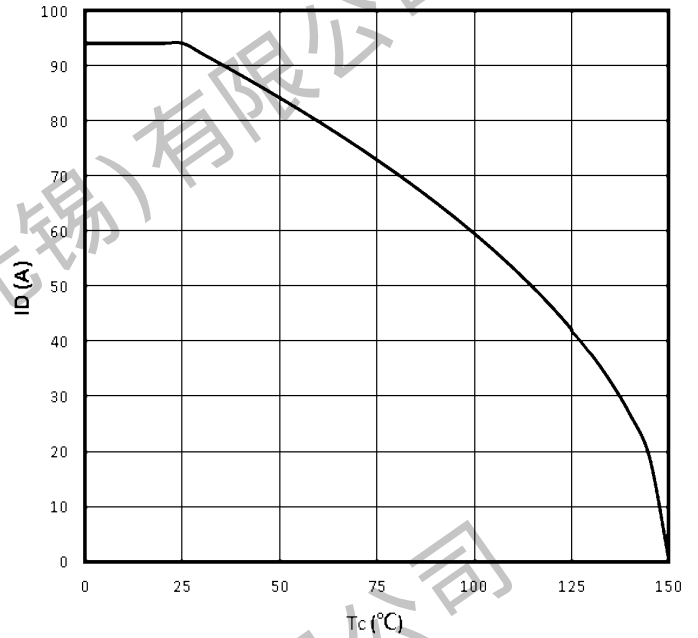

Safe operating area
 $I_D=f(V_{DS})$

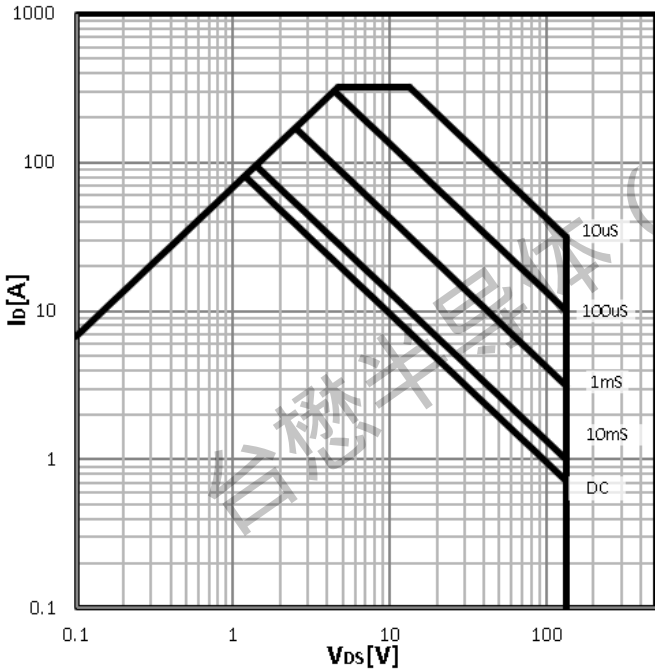

Body Diode Forward Voltage Variation
 $I_F=f(V_{GS})$

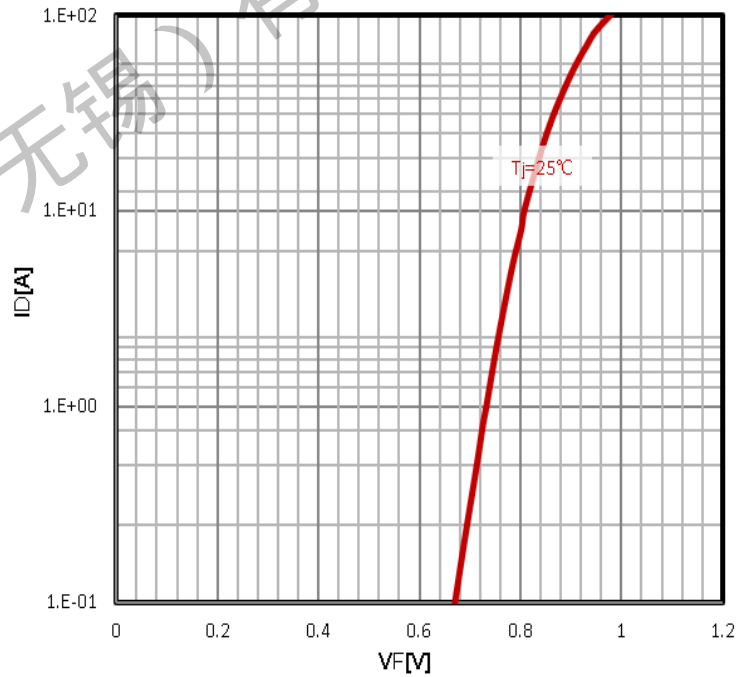

TMG130N12HP

N-Channel Enhancement Mosfet

Max. transient thermal impedance

$$Z_{thJC} = f(t_p)$$

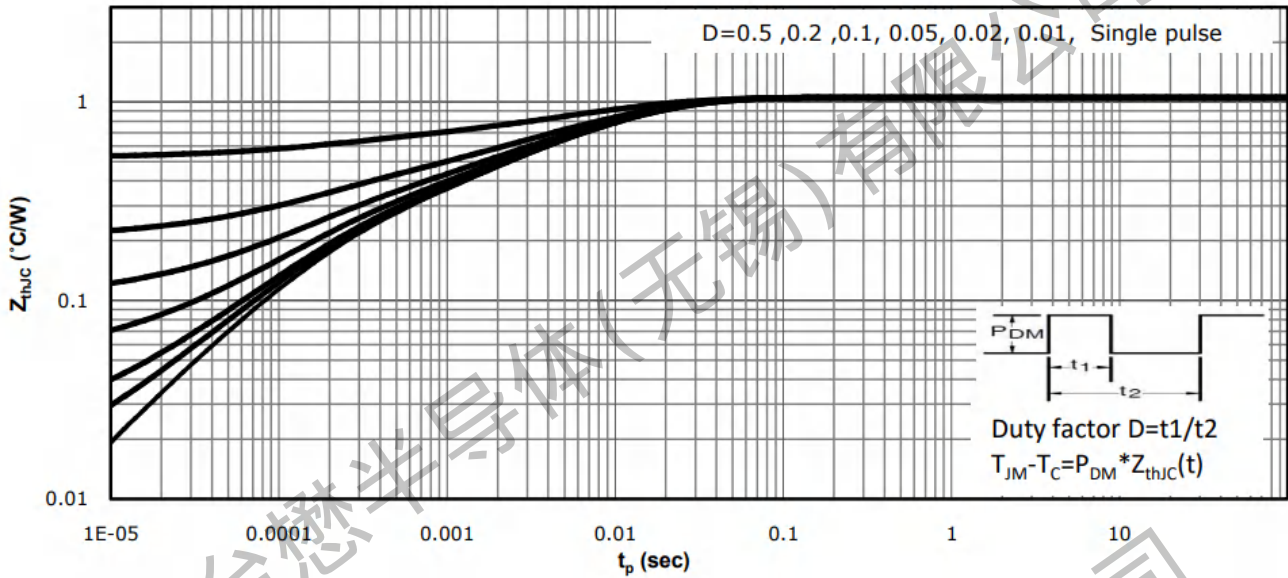

TMG130N12HP

N-Channel Enhancement Mosfet

Package Mechanical Data: TO-220AB

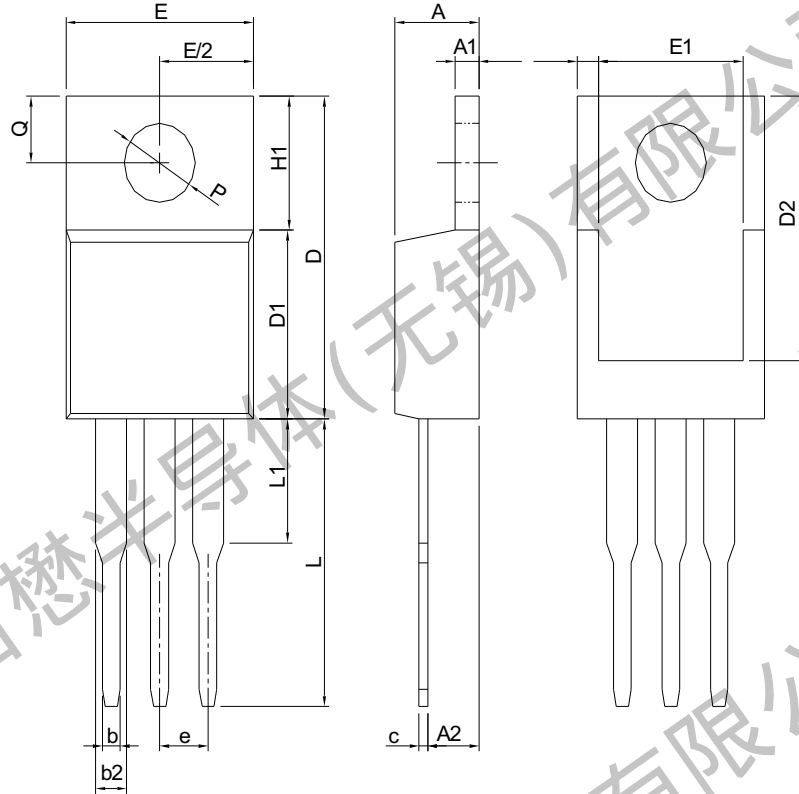

DIMENSIONS	TO-220			
	MILLIMETERS		INCHES	
	MIN.	MAX.	MIN.	MAX.
A	3.56	4.83	0.140	0.190
A1	0.51	1.40	0.020	0.055
A2	2.03	2.92	0.080	0.115
b	0.38	1.02	0.015	0.040
b2	1.14	1.78	0.045	0.070
c	0.36	0.61	0.014	0.024
D	14.22	16.51	0.560	0.650
D1	8.38	9.02	0.330	0.355
D2	12.19	13.65	0.480	0.537
E	9.65	10.67	0.380	0.420
E1	6.86	8.89	0.270	0.350
e	2.54 BSC		0.100 BSC	
H1	5.84	6.86	0.230	0.270
L	12.70	14.73	0.500	0.580
L1	-	6.35	-	0.250
P	3.53	4.09	0.139	0.161
Q	2.54	3.43	0.100	0.135

RECOMMENDED LAND PATTERN

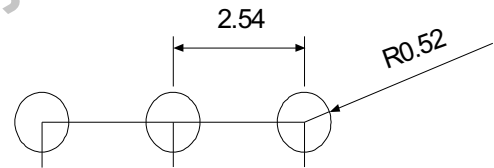

UNIT: mm

Note: Follow JEDEC TO-220 AB.

TMG130N12HP

N-Channel Enhancement Mosfet

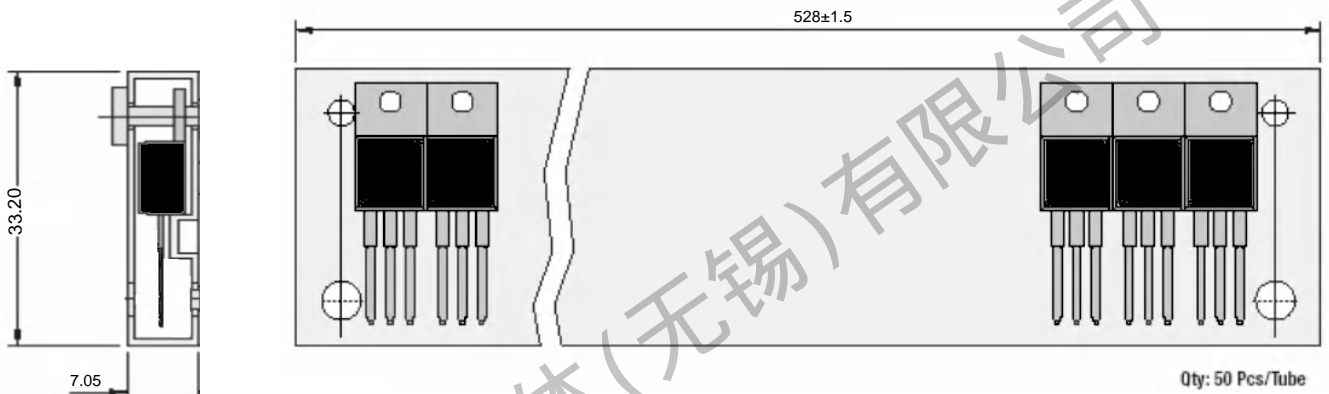

All Dimensions are in mm

1.TO-220AB Packaging

Package	Packing Form	Quantity		
		Tube	Inner Box [kpcs]	Outbox [kpcs]
TO-220AB	Tube Tape	50	5	1



TMG130N12HP

N-Channel Enhancement Mosfet

Inner Box

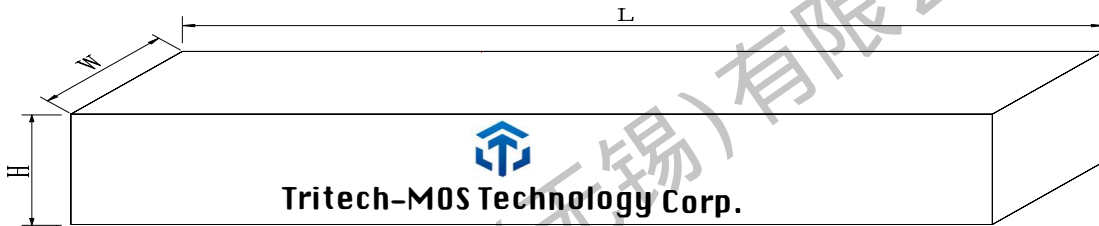

Dimension : 580 (L)×154(W) ×49(H) mm

Quantity : 50 ×20Ea = 1Kpcs

Outer Box

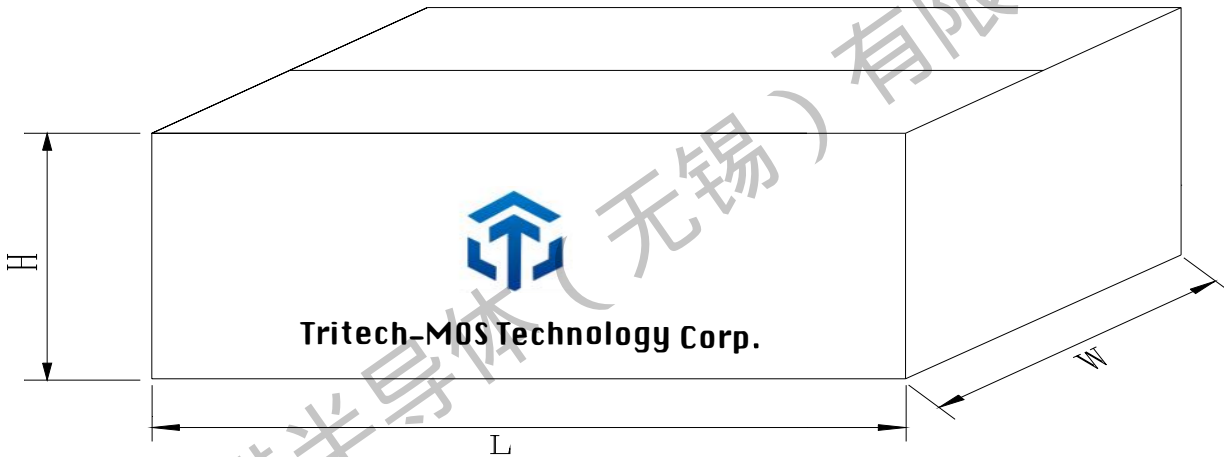

Dimension : 595(L)×285(W) ×185(H) mm

Quantity : 1K×5Ea = 5Kpcs

Important Notices and Disclaimers

- Tritech-MOS Technology Corp. reserves the right to change this document, its products, and specifications at any time without prior notice.
- Before final design, purchase, or use, customers should obtain and confirm the latest product information and specifications.
- Tritech-MOS Technology Corp. makes no warranties, representations or warranties regarding the suitability of its products for any specific purpose, and Tritech-MOS Technology Corp. does not assume any responsibility for application assistance or customer product design.
- Tritech-MOS Technology Corp. does not guarantee or assume any responsibility for the purchase or use of any unexpected or unauthorized products.
- Any intellectual property rights of Tritech-MOS Technology Corp. are not licensed through implicate or other means.
- Products of Tritech-MOS Technology Corp. are not included as critical components in life support equipment or systems without explicit written approval from Tritech-MOS Technology Corp.

Revision history:

Date	Rev	Description	Page
2024.06.08	24.06	Original	