

**TM50N06NF**

**N-Channel Enhancement Mosfet**

<p><b>General Description</b></p> <ul style="list-style-type: none"> <li>• Low <math>R_{DS(ON)}</math></li> <li>• RoHS and Halogen-Free Compliant</li> </ul> <p><b>Applications</b></p> <ul style="list-style-type: none"> <li>• Load switch</li> <li>• PWM</li> </ul>	<p><b>General Features</b></p> <p><math>V_{DS} = 60V</math> <math>I_D = 50A</math></p> <p><math>R_{DS(ON)} = 12 m\Omega (typ.) @ V_{GS} = 10V</math></p> <p>100% UIS Tested 100% <math>R_g</math> Tested</p> 
------------------------------------------------------------------------------------------------------------------------------------------------------------------------------------------------------------------------------------------------------------------------	------------------------------------------------------------------------------------------------------------------------------------------------------------------------------------------------------------------------------------------------------------------------------------------------------

NF:DFN5x6-8L

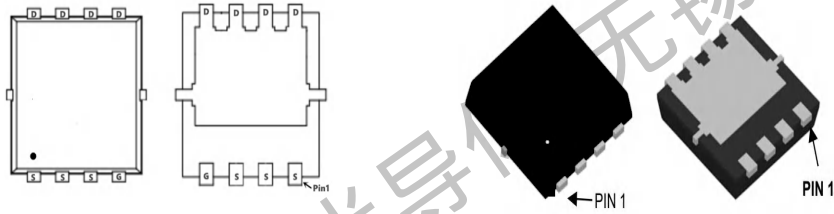

Marking:50N06

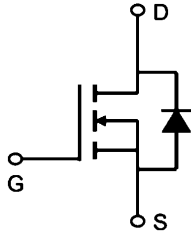

**Absolute Maximum Ratings** ( $T_c=25^\circ C$  unless otherwise noted)

Symbol	Parameter	Rating	Units
$V_{DS}$	Drain-Source Voltage	60	V
$V_{GS}$	Gate-Source Voltage	$\pm 20$	V
$I_D @ T_c=25^\circ C$	Continuous Drain Current, $V_{GS} @ 10V$	50	A
$I_D @ T_c=100^\circ C$	Continuous Drain Current, $V_{GS} @ 10V$	32	A
$I_{DM}$	Pulsed Drain Current	370	A
EAS	Single Pulse Avalanche Energy	98	mJ
$P_D @ T_c=25^\circ C$	Total Power Dissipation	62.5	W
$T_{STG}$	Storage Temperature Range	-55 to 150	$^\circ C$
$T_J$	Operating Junction Temperature Range	-55 to 150	$^\circ C$

**Thermal Data**

Symbol	Parameter	Typ.	Max.	Unit
$R_{\theta JA}$	Thermal Resistance Junction-Ambient	---	62	$^\circ C/W$
$R_{\theta JC}$	Thermal Resistance Junction-Case	---	3.6	$^\circ C/W$



# TM50N06NF

## N-Channel Enhancement Mosfet

Electrical Characteristics: ( $T_C=25^\circ\text{C}$  unless otherwise noted)

Symbol	Parameter	Conditions	Min	Typ	Max	Units
<b>Off Characteristics</b>						
$BV_{DSS}$	Drain-Source Breakdown Voltage	$V_{GS}=0V, I_D=250\ \mu\text{A}$	60	---	---	V
$I_{DSS}$	Zero Gate Voltage Drain Current	$V_{GS}=0V, V_{DS}=60V, T_J=25^\circ\text{C}$	---	---	1	$\mu\text{A}$
$I_{GSS}$	Gate-Source Leakage Current	$V_{GS}=\pm 20V, V_{DS}=0V$	---	---	$\pm 100$	nA
<b>On Characteristics</b>						
$V_{GS(th)}$	Drain-to-Source Leakage Current	$V_{DS} = V_{GS}, I_D = 250\mu\text{A}$	1.0	2.0	3.0	V
$R_{DS(on)}$	Drain-Source On Resistance	$V_{GS}=10V, I_D=20A$	---	12	17	m $\Omega$
		$V_{GS}=4.5V, I_D=20A$	---	16	21	
$R_G$	Gate Resistance	f = 1.0MHz open drain	---	1.4	---	$\Omega$
<b>Dynamic Characteristics</b>						
$C_{iss}$	Input Capacitance	$V_{DS}=30V, V_{GS}=0V, f=1\text{MHz}$	---	1880	---	pF
$C_{oss}$	Output Capacitance		---	110	---	
$C_{rss}$	Reverse Transfer Capacitance		---	88	---	
<b>Switching Characteristics</b>						
$t_{d(on)}$	Turn-On Delay Time	$V_{DS}=30V, V_{GS}=10V, R_G=3\ \Omega, I_D=20A$	---	10	---	ns
$t_r$	Rise Time		---	23	---	ns
$t_{d(off)}$	Turn-Off Delay Time		---	58	---	ns
$t_f$	Fall Time		---	8	---	ns
$Q_g$	Total Gate Charge	$V_{GS}=10V, V_{DS}=30V, I_D=20A$	---	37	---	nC
$Q_{gs}$	Gate-Source Charge		---	7.5	---	nC
$Q_{gd}$	Gate-Drain "Miller" Charge		---	8	---	nC
<b>Drain-Source Diode Characteristics</b>						
Symbol	Parameter	Conditions	Min	Typ	Max	Units
$V_{SD}$	Forward Voltage	$V_{GS}=0V, I_S=20A, T_J=25^\circ\text{C}$	---	1.2	---	V
$I_S$	Continuous Diode Forward Current		---	---	50	A
$t_{rr}$	Continuous Source Current	$V_{GS} = 0V, I_F = 20A,$	---	29	---	ns
$q_{rr}$	Pulsed Source Current	$dI_S/dt = 100A/\mu\text{s},$	---	21	---	nC



TM50N06NF

N-Channel Enhancement Mosfet

Typical Characteristics

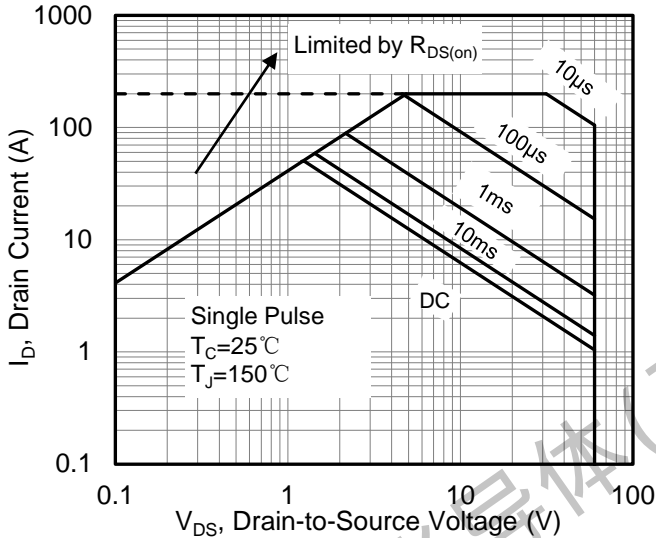

Figure 1. Maximum Safe Operating Area

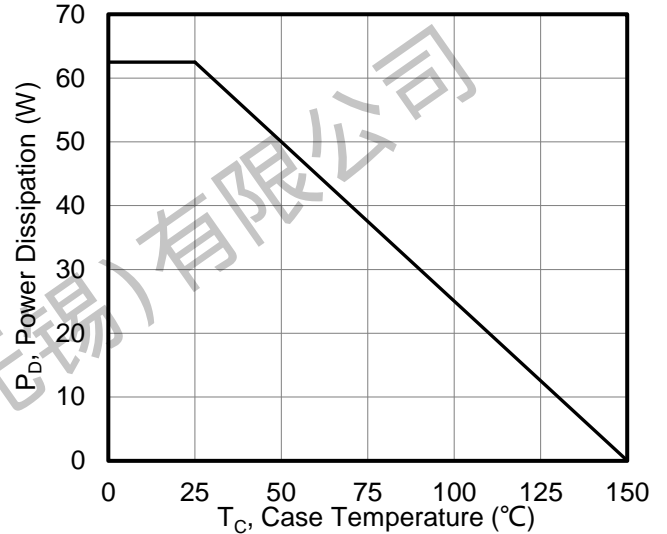

Figure 2. Maximum Power Dissipation vs Case Temperature

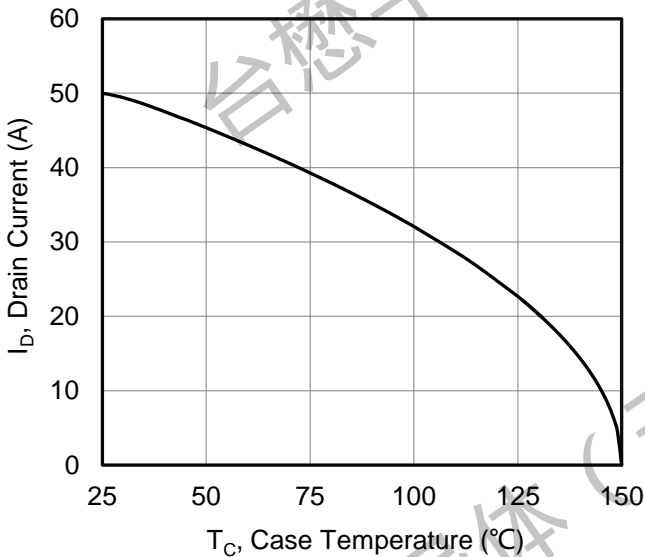

Figure 3. Maximum Continuous Drain Current vs

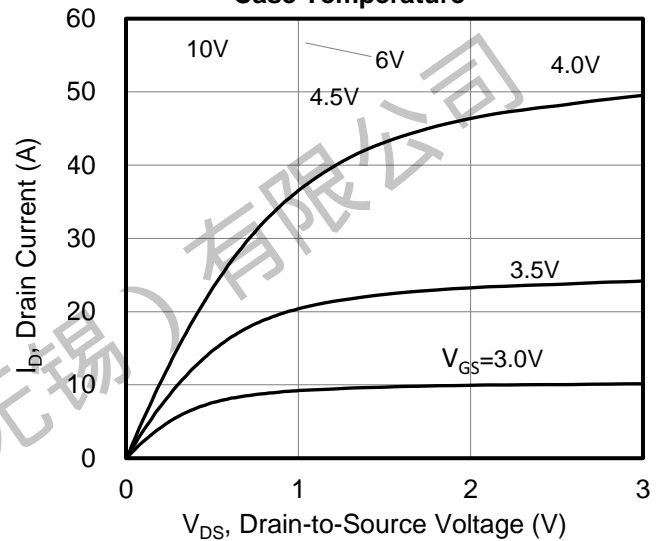

Figure 4. Typical output Characteristics

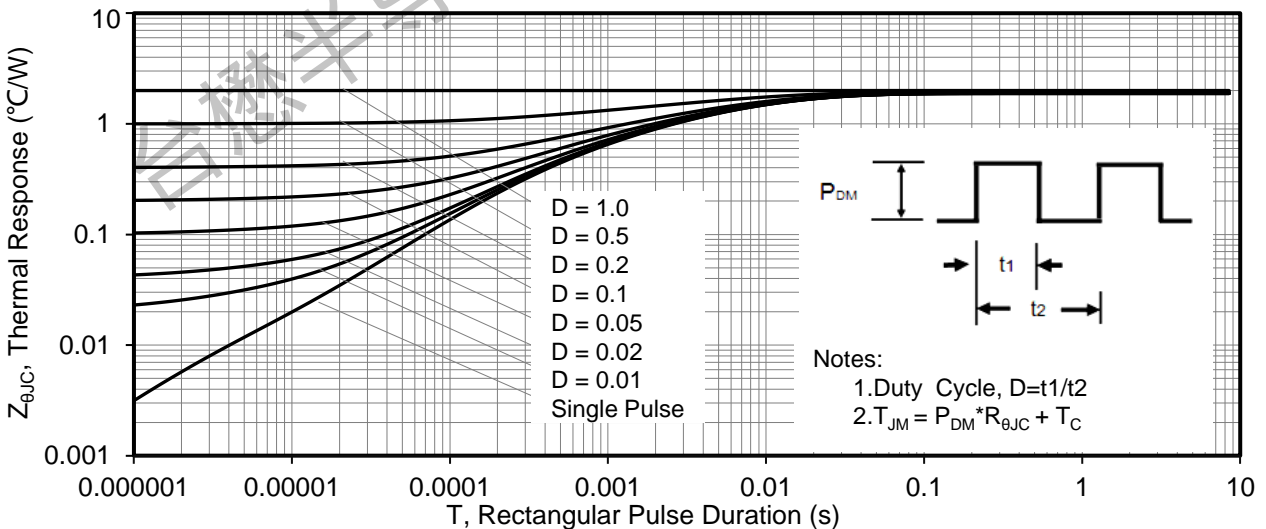

Figure 5. Maximum Effective Thermal Impedance, Junction to Case



TM50N06NF

N-Channel Enhancement Mosfet

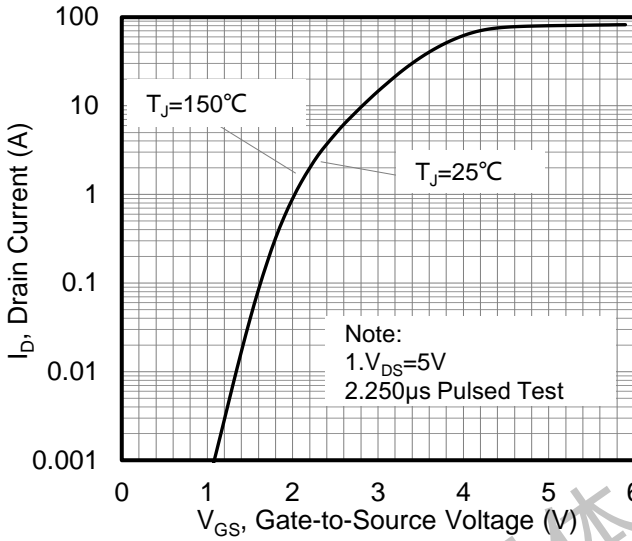

Figure 6. Typical Transfer Characteristics

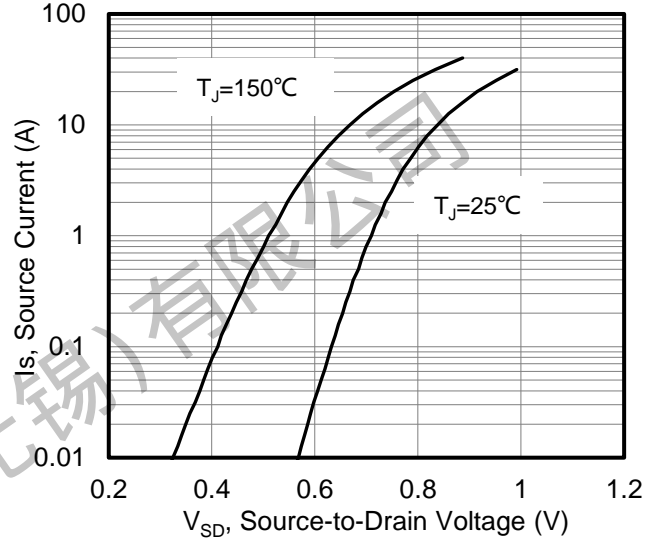

Figure 7. Typical Body Diode Transfer Characteristics

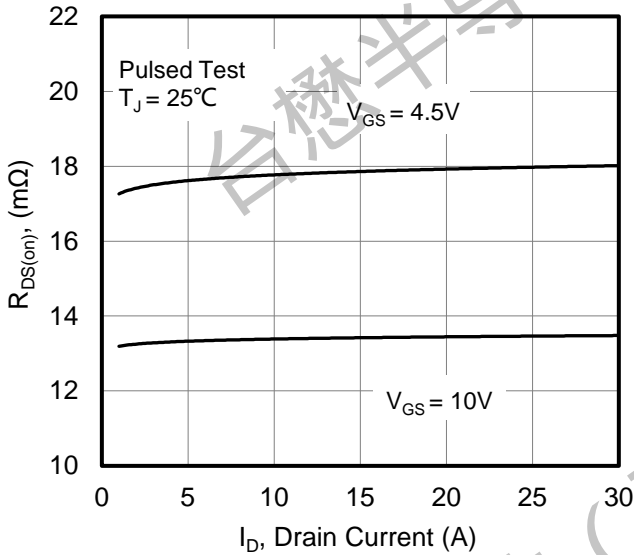

Figure 8. Drain-to-Source On Resistance vs Drain Current

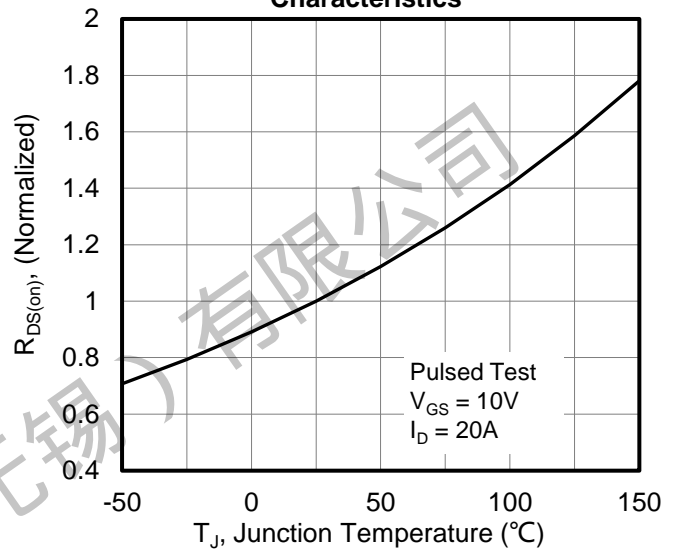

Figure 9. Normalized On Resistance vs Junction Temperature

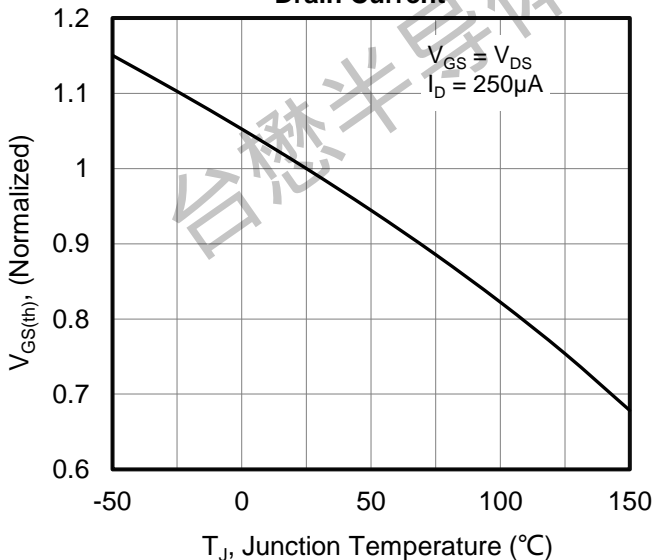

Figure 10. Normalized Threshold Voltage vs Junction Temperature

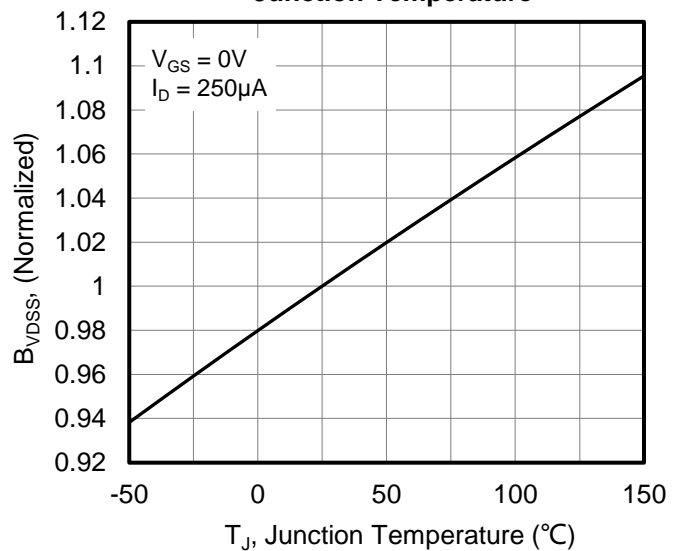

Figure 11. Normalized Breakdown Voltage vs Junction Temperature



# TM50N06NF

## N-Channel Enhancement Mosfet

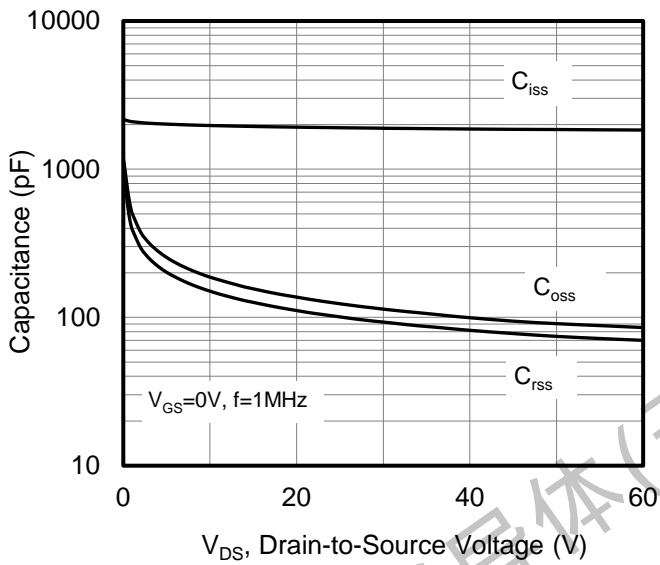

Figure 12. Capacitance Characteristics

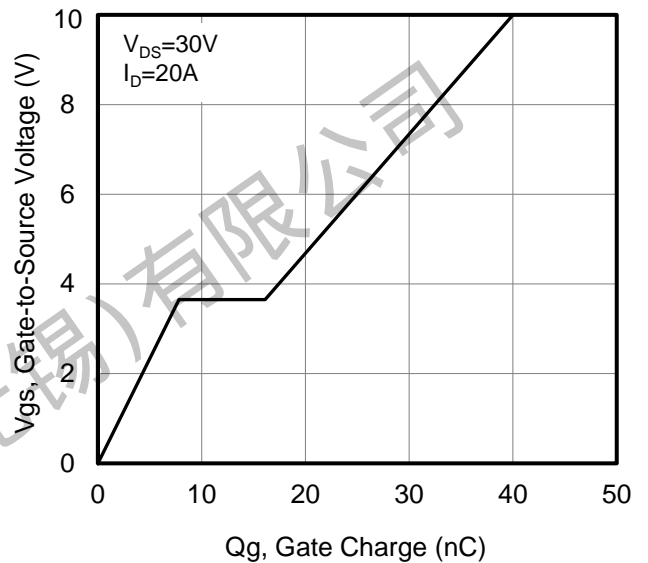

Figure 13. Typical Gate Charge vs Gate to Source Voltage



**TM50N06NF**

**N-Channel Enhancement Mosfet**

**Package Mechanical Data:DFN5x6-8L**

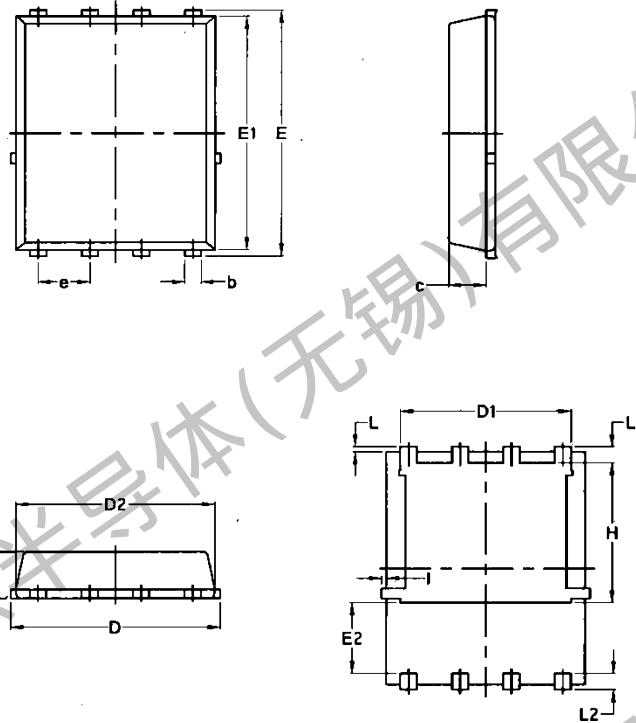

Symbol	Common			
	mm		Inch	
	Min	Max	Min	Max
A	1.03	1.17	0.0406	0.0461
b	0.34	0.48	0.0134	0.0189
c	0.824	0.0970	0.0324	0.082
D	4.80	5.40	0.1890	0.2126
D1	4.11	4.31	0.1618	0.1697
D2	4.80	5.00	0.1890	0.1969
E	5.95	6.15	0.2343	0.2421
E1	5.65	5.85	0.2224	0.2303
E2	1.60	/	0.0630	/
e	1.27 BSC		0.05 BSC	
L	0.05	0.25	0.0020	0.0098
L1	0.38	0.50	0.0150	0.0197
L2	0.38	0.50	0.0150	0.0197
H	3.30	3.50	0.1299	0.1378
I	/	0.18	/	0.0070

**TM50N06NF**

**N-Channel Enhancement Mosfet**

PDFN5x6-8L Embossed Carrier Tape

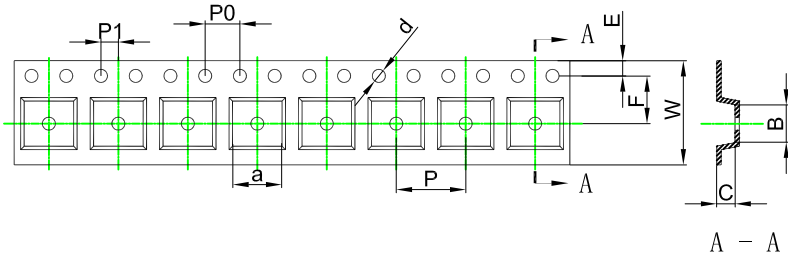

**Packaging Description:**  
SOP-8L parts are shipped in tape. The carrier tape is made from a dissipative (carbon filled) polycarbonate resin. The cover tape is a multilayer film (Heat Activated Adhesive in nature) primarily composed of polyester film, adhesive layer, sealant, and anti-static sprayed agent. These reeled parts in standard option are shipped with 2,500 units per 13" or 33cm diameter reel. The reels are clear in color and is made of polystyrene plastic (anti-static coated).  
**ALL DIM IN mm**

Dimensions are in millimeter										
Pkg type	a	B	C	d	E	F	P0	P	P1	W
PDFN5x6-8L	6.40	5.40	2.10	Ø1.50	1.75	5.50	4.00	8.00	2.00	12.00

PDFN5x6-8L Tape Leader and Trailer

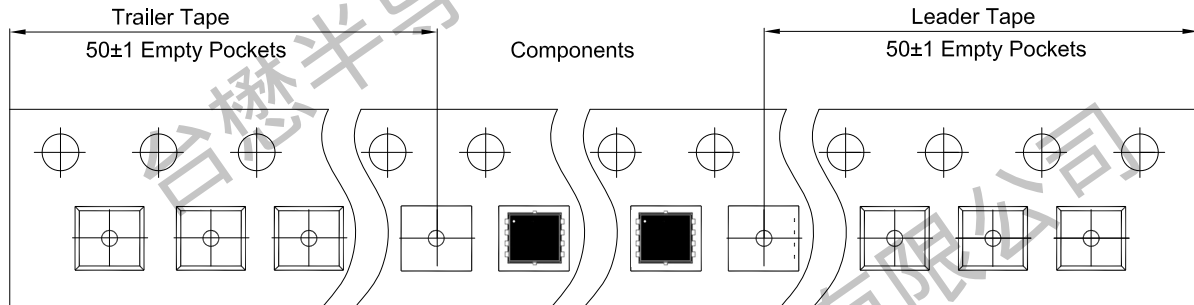

PDFN5x6-8L Reel

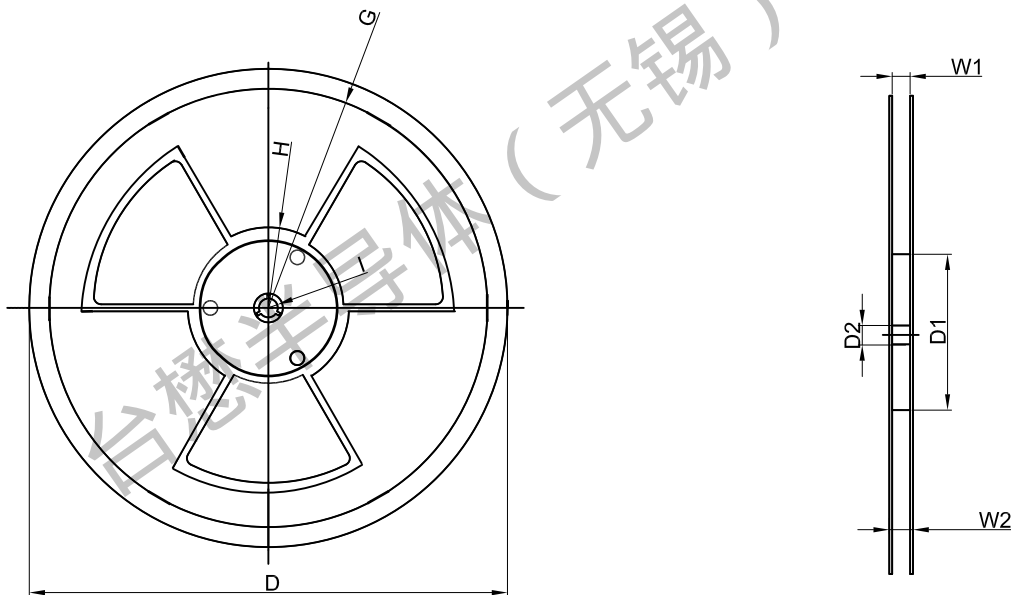

Dimensions are in millimeter								
Reel Option	D	D1	D2	G	H	I	W1	W2
13"Dia	Ø330.00	100.00	13.00	R135.00	R55.00	R6.50	12.00	14.00

REEL	Reel Size	Box	Box Size(mm)	Carton	Carton Size(mm)	G.W.(kg)
5,000 pcs	13 inch	10,000 pcs	370×355×52	50,000 pcs	400×360×368	



## TM50N06NF

## N-Channel Enhancement Mosfet

### Important Notices and Disclaimers

- Tritech-MOS Technology Corp. reserves the right to change this document, its products, and specifications at any time without prior notice.
- Before final design, purchase, or use, customers should obtain and confirm the latest product information and specifications.
- Tritech-MOS Technology Corp. makes no warranties, representations or warranties regarding the suitability of its products for any specific purpose, and Tritech-MOS Technology Corp. does not assume any responsibility for application assistance or customer product design.
- Tritech-MOS Technology Corp. does not guarantee or assume any responsibility for the purchase or use of any unexpected or unauthorized products.
- Any intellectual property rights of Tritech-MOS Technology Corp. are not licensed through implicate or other means.
- Products of Tritech-MOS Technology Corp. are not included as critical components in life support equipment or systems without explicit written approval from Tritech-MOS Technology Corp.

Revision history:

Date	Rev	Description	Page
2023.09.12	23.09	Original	