



TM4606C

N+P-Channel Enhancement Mode Mosfet

<p>General Description</p> <ul style="list-style-type: none"> • Low $R_{DS(ON)}$ • RoHS and Halogen-Free Compliant <p>Applications</p> <ul style="list-style-type: none"> • Load switch • PWM 	<p>General Features</p> <p>N Channel $V_{DS} = 20V, I_D = 3.0A$ $R_{DS(ON)} = 43m\Omega (typ.) @ V_{GS} = 4.5V$</p> <p>P Channel $V_{DS} = -20V, I_D = -3.0A$ $R_{DS(ON)} = 80m\Omega (typ.) @ V_{GS} = -4.5V$</p> <p>100% UIS Tested 100% R_g Tested</p> 
------------------------------------------------------------------------------------------------------------------------------------------------------------------------------------------------------------------------------------------------------------------------	--------------------------------------------------------------------------------------------------------------------------------------------------------------------------------------------------------------------------------------------------------------------------------------------------------------------------------------------------------------------------------------------------------------------------------------------------------------

S:SOP-8L

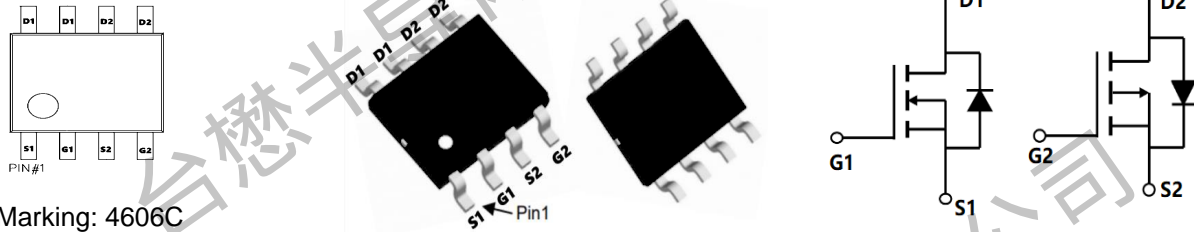

Marking: 4606C

Absolute Maximum Ratings ($T_A = 25^\circ C$ unless otherwise noted)

Symbol	Parameter	Rating		Units
		N-Channel	P-Channel	
V_{DS}	Drain-Source Voltage	20	-20	V
V_{GS}	Gate-Source Voltage	± 12	± 12	V
$I_D @ T_A = 25^\circ C$	Continuous Drain Current, $V_{GS} @ 4.5V$	3	-3	A
$I_D @ T_A = 70^\circ C$	Continuous Drain Current, $V_{GS} @ 4.5V$	2	-2	A
I_{DM}	Pulsed Drain Current ¹	12	-10	A
$P_D @ T_C = 25^\circ C$	Total Power Dissipation	2.5	2.08	W
T_{STG}	Storage Temperature Range	-55 to 175	-55 to 175	$^\circ C$
T_J	Operating Junction Temperature Range	-55 to 175	-55 to 175	$^\circ C$

Thermal Data

Symbol	Parameter	Typ.	Max.	Unit
$R_{\theta JA}$	Thermal Resistance Junction-Ambient ²	---	85	$^\circ C/W$
$R_{\theta JC}$	Thermal Resistance Junction-Case	---	62.5	$^\circ C/W$



TM4606C

N+P-Channel Enhancement Mode Mosfet

N-Channel Electrical Characteristics (T_J=25 °C, unless otherwise noted)

Symbol	Parameter	Test Condition	Min.	Typ.	Max.	Units
Off Characteristic						
V _{(BR)DSS}	Drain-Source Breakdown Voltage	V _{GS} =0V, I _D =250μA	20	-	-	V
I _{DSS}	Zero Gate Voltage Drain Current	V _{DS} =20V, V _{GS} = 0V,	-	-	1.0	μA
I _{GSS}	Gate to Body Leakage Current	V _{DS} =0V, V _{GS} = ±12V	-	-	±100	nA
On Characteristics						
V _{GS(th)}	Gate Threshold Voltage	V _{DS} = V _{GS} , I _D =250μA	0.4	0.75	1.0	V
R _{DS(on)}	Static Drain-Source on-Resistance note2	V _{GS} =4.5V, I _D =3A	-	43	63	mΩ
		V _{GS} =2.5V, I _D =2A	-	62	70	
Dynamic Characteristics						
C _{iss}	Input Capacitance	V _{DS} =10V, V _{GS} =0V, f = 1.0MHz	-	184	-	pF
C _{oss}	Output Capacitance		-	38	-	pF
C _{rss}	Reverse Transfer Capacitance		-	28	-	pF
Q _g	Total Gate Charge	V _{DS} =10V, I _D =3A, V _{GS} =4.5V	-	2.7	-	nC
Q _{gs}	Gate-Source Charge		-	0.4	-	nC
Q _{gd}	Gate-Drain("Miller") Charge		-	0.5	-	nC
Switching Characteristics						
t _{d(on)}	Turn-on Delay Time	V _{DS} =10V, I _D =3A, R _{GEN} =3Ω, V _{GS} =4.5V	-	8	-	ns
t _r	Turn-on Rise Time		-	27	-	ns
t _{d(off)}	Turn-off Delay Time		-	26	-	ns
t _f	Turn-off Fall Time		-	33	-	ns
Drain-Source Diode Characteristics and Maximum Ratings						
I _S	Maximum Continuous Drain to Source Diode Forward Current		-	-	3	A
I _{SM}	Maximum Pulsed Drain to Source Diode Forward Current		-	-	12	A
V _{SD}	Drain to Source Diode Forward Voltage	V _{GS} = 0V, I _S =3A	-	-	1.2	V

Notes:1. Repetitive Rating: Pulse Width Limited by Maximum Junction Temperature

2. Pulse Test: Pulse Width≤300μs, Duty Cycle≤0.5%



TM4606C

N+P-Channel Enhancement Mode Mosfet

P-Channel Electrical Characteristics (T_J=25 °C, unless otherwise noted)

Symbol	Parameter	Test Condition	Min.	Typ.	Max.	Units
Off Characteristic						
V _{(BR)DSS}	Drain-Source Breakdown Voltage	V _{GS} =0V, I _D = -250μA	-20	-	-	V
I _{DSS}	Zero Gate Voltage Drain Current	V _{DS} = -20V, V _{GS} = 0V,	-	-	-1	μA
I _{GSS}	Gate to Body Leakage Current	V _{DS} =0V, V _{GS} = ±12V	-	-	±100	nA
On Characteristics						
V _{GS(th)}	Gate Threshold Voltage	V _{DS} = V _{GS} , I _D = -250μA	-0.3	-0.65	-1.0	V
R _{DS(on)}	Static Drain-Source on-Resistance note2	V _{GS} = -4.5V, I _D = -2.5A	-	80	109	mΩ
		V _{GS} = -2.5V, I _D = -1.5A	-	110	125	
Dynamic Characteristics						
C _{iss}	Input Capacitance	V _{DS} = -10V, V _{GS} = 0V, f = 1.0MHz	-	248	-	pF
C _{oss}	Output Capacitance		-	42	-	pF
C _{rss}	Reverse Transfer Capacitance		-	31	-	pF
Q _g	Total Gate Charge	V _{DS} = -10V, I _D = -2.5A, V _{GS} = -4.5V	-	2.9	-	nC
Q _{gs}	Gate-Source Charge		-	0.45	-	nC
Q _{gd}	Gate-Drain("Miller") Charge		-	0.75	-	nC
Switching Characteristics						
t _{d(on)}	Turn-on Delay Time	V _{DD} = -10V, R _L =5Ω, R _{GEN} =3Ω, V _{GS} =-4.5V,	-	9.8	-	ns
t _r	Turn-on Rise Time		-	4.9	-	ns
t _{d(off)}	Turn-off Delay Time		-	20.5	-	ns
t _f	Turn-off Fall Time		-	7	-	ns
Drain-Source Diode Characteristics and Maximum Ratings						
I _S	Maximum Continuous Drain to Source Diode Forward Current		-	-	-3.0	A
I _{SM}	Maximum Pulsed Drain to Source Diode Forward Current		-	-	-10	A
V _{SD}	Drain to Source Diode Forward Voltage	V _{GS} = 0V, I _S = -2.5A	-	-	-1.2	V

Notes:1. Repetitive Rating: Pulse Width Limited by Maximum Junction Temperature

2. Pulse Test: Pulse Width≤300μs, Duty Cycle≤2%

TM4606C

N+P-Channel Enhancement Mode Mosfet

N-Channel Typical Characteristics

Figure 1: Output Characteristics

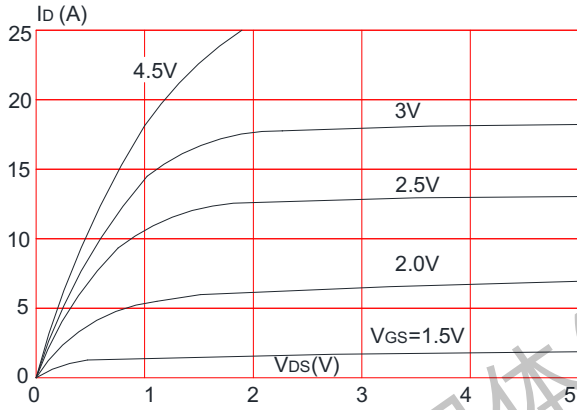

Figure 2: Typical Transfer Characteristics

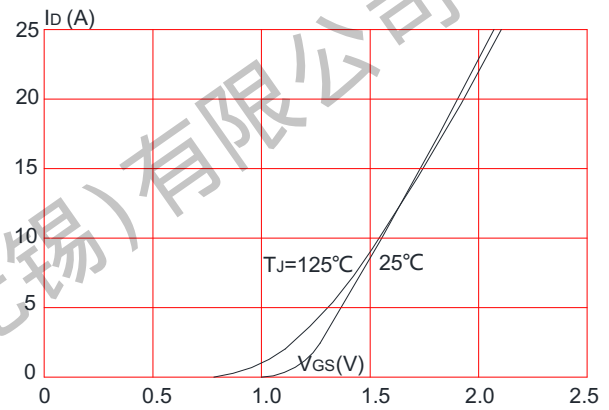

Figure 3: On-resistance vs. Drain Current

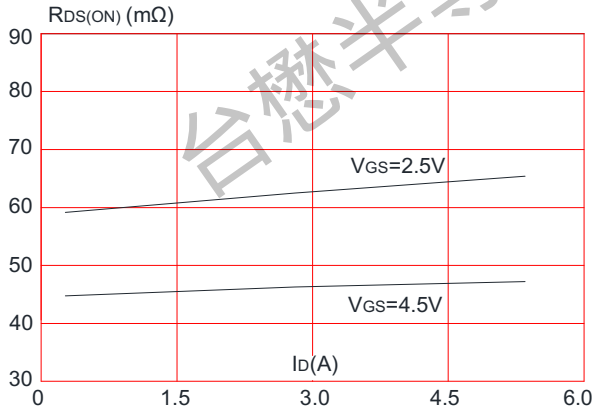

Figure 4: Body Diode Characteristics

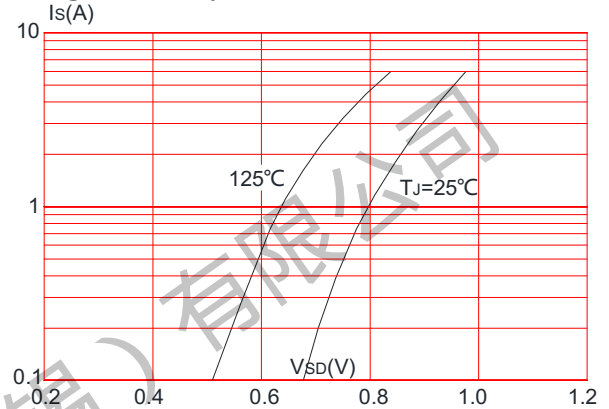

Figure 5: Gate Charge Characteristics

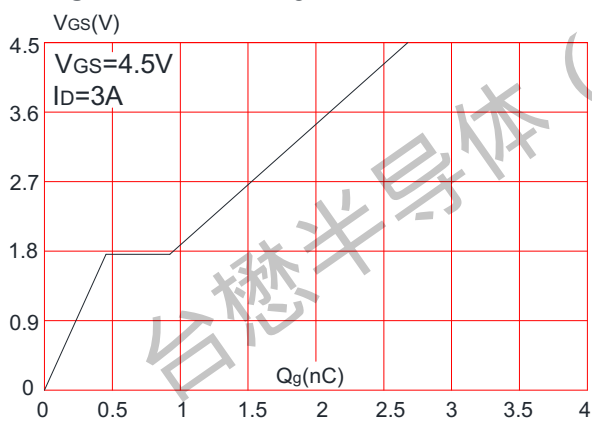
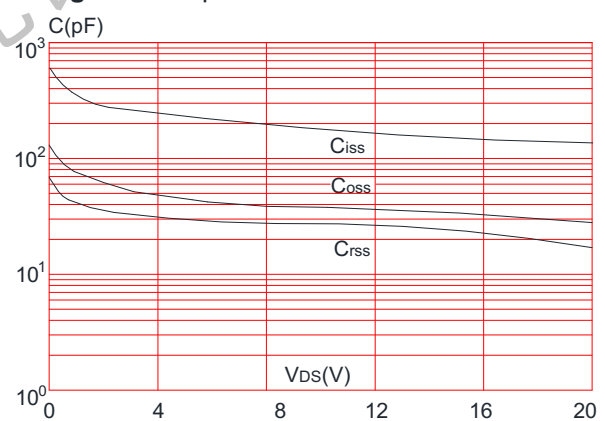

Figure 6: Capacitance Characteristics



TM4606C

N+P-Channel Enhancement Mode Mosfet

N-Channel Typical Characteristics

Figure 7: Normalized Breakdown Voltage vs. Junction Temperature

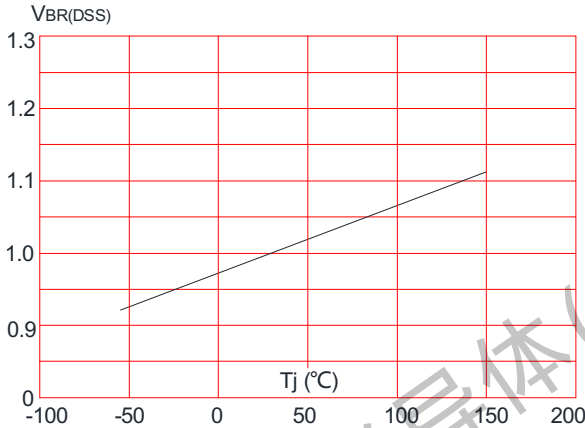

Figure 8: Normalized on Resistance vs. Junction Temperature

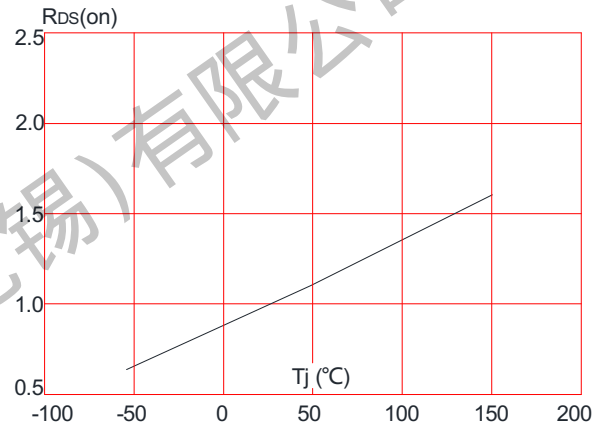

Figure 9: Maximum Safe Operating Area

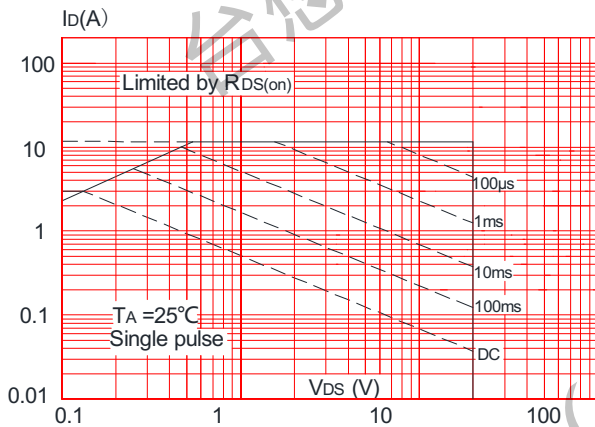

Figure 10: Maximum Continuous Drain Current vs. Ambient Temperature

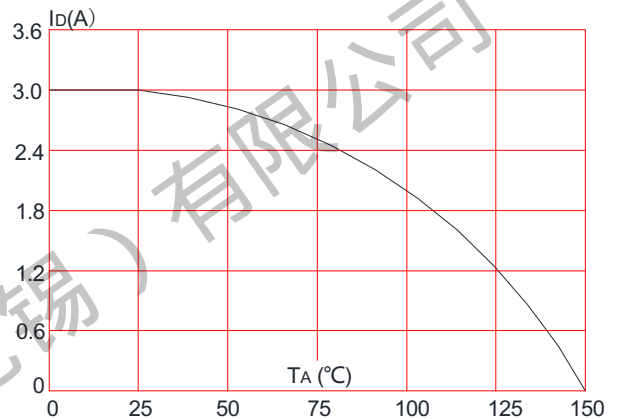
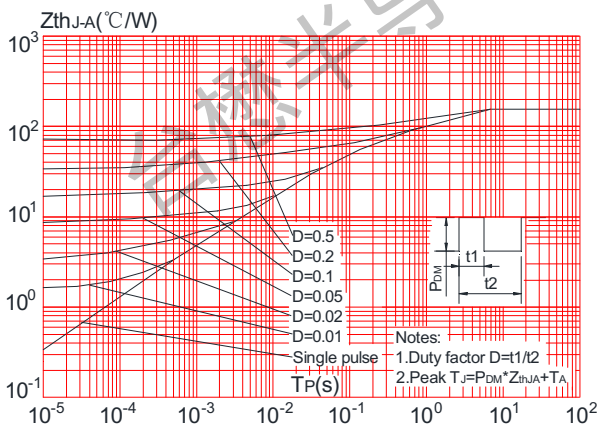

Figure.11: Maximum Effective Transient Thermal Impedance, Junction-to-Ambient



TM4606C

N+P-Channel Enhancement Mode Mosfet

P-Channel Typical Characteristics

Figure 1: Output Characteristics

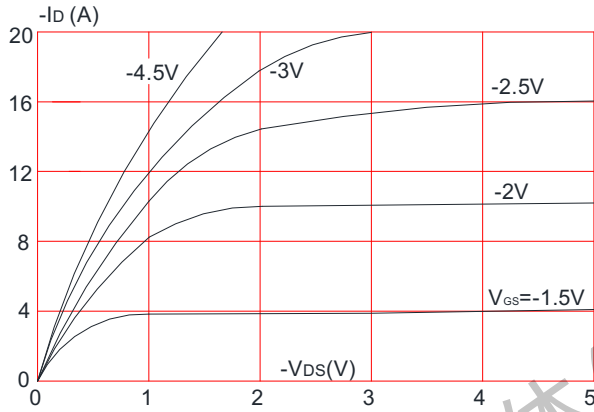

Figure 2: Typical Transfer Characteristics

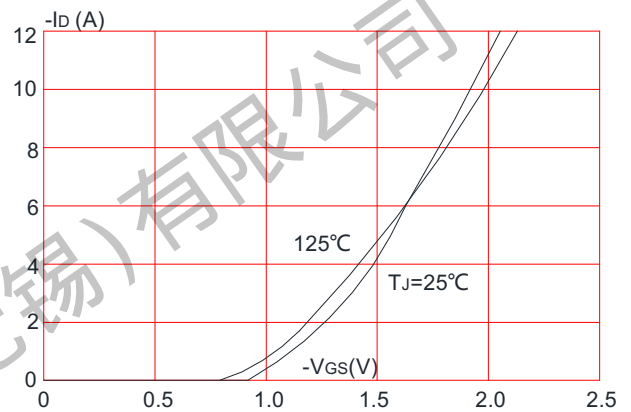

Figure 3: On-resistance vs. Drain Current

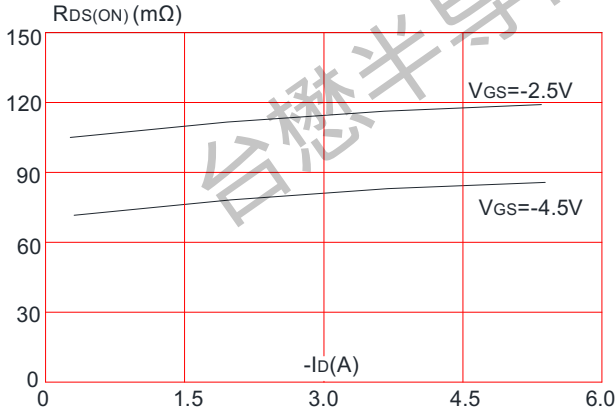

Figure 4: Body Diode Characteristics

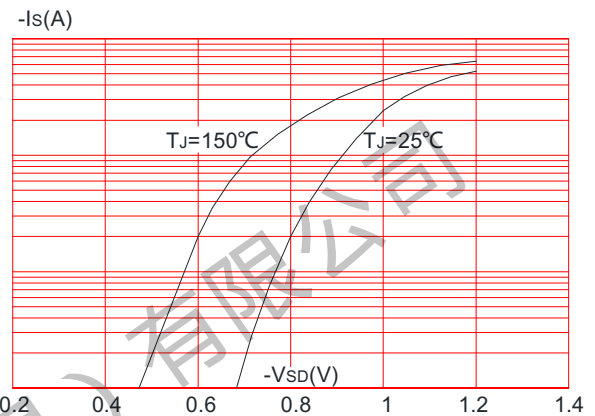

Figure 5: Gate Charge Characteristics

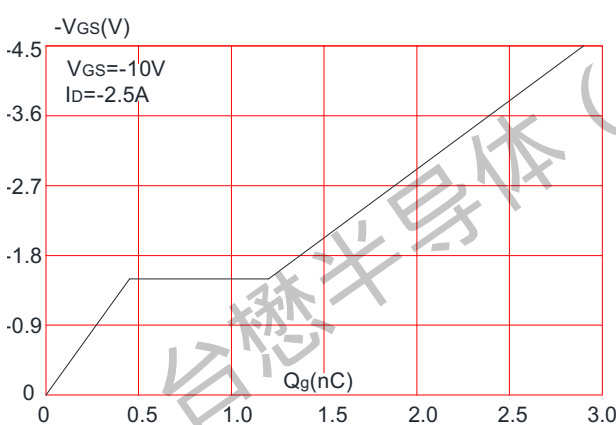
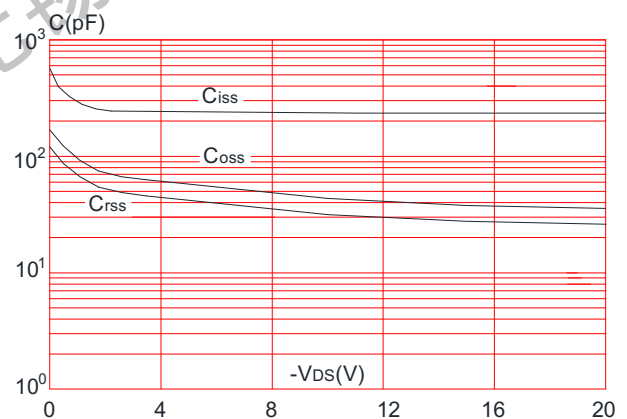

Figure 6: Capacitance Characteristics



TM4606C

N+P-Channel Enhancement Mode Mosfet

P-Channel Typical Characteristics

Figure 7: Normalized Breakdown Voltage vs. Junction Temperature

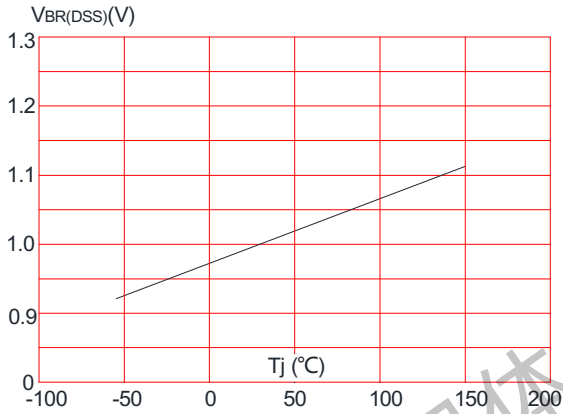

Figure 8: Normalized on Resistance vs. Junction Temperature

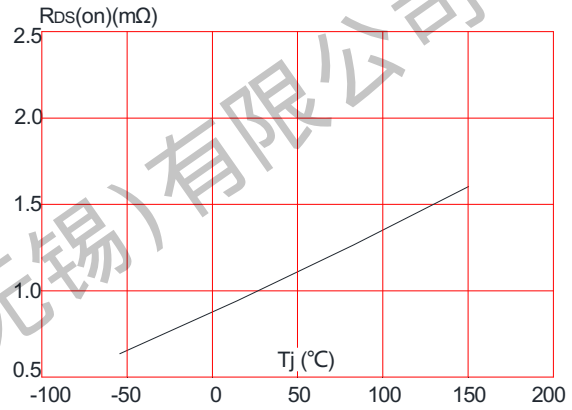

Figure 9: Maximum Safe Operating Area

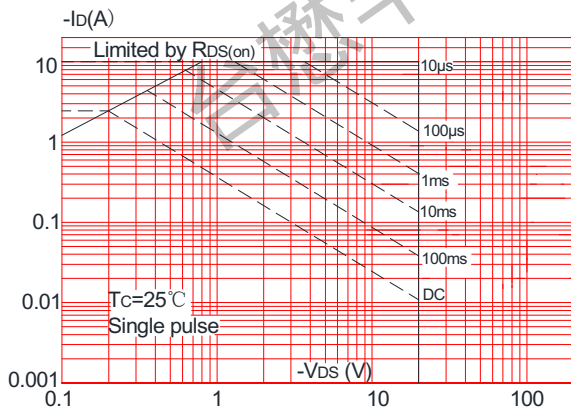

Figure 10: Maximum Continuous Drain Current vs. Case Temperature

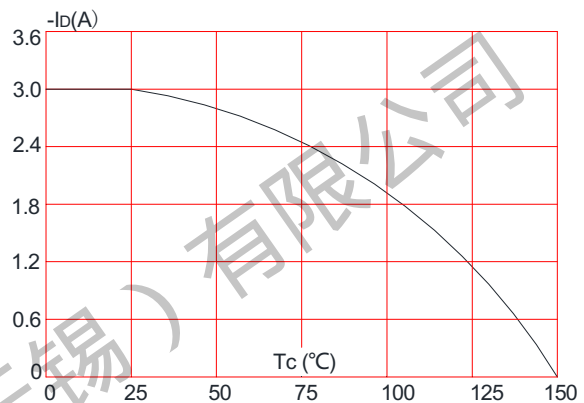
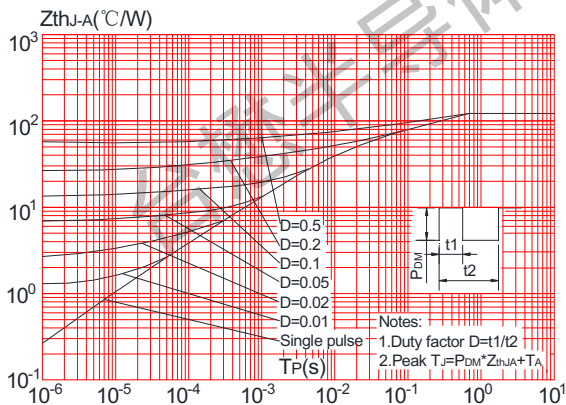

Figure.11: Maximum Effective Transient Thermal Impedance, Junction-to-Ambient





TM4606C

N+P-Channel Enhancement Mode Mosfet

Package Mechanical Data:SOP-8L

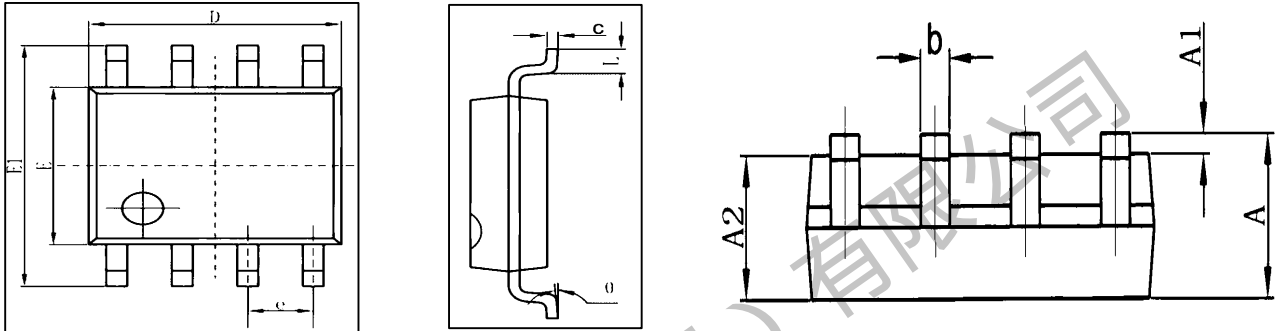

Symbol	Dimensions In Millimeters		Dimensions In Inches	
	Min	Max	Min	Max
A	1.350	1.750	0.053	0.069
A1	0.100	0.250	0.004	0.010
A2	1.350	1.550	0.053	0.061
b	0.330	0.510	0.013	0.020
c	0.170	0.250	0.006	0.010
D	4.700	5.100	0.185	0.200
E	3.800	4.000	0.150	0.157
E1	5.800	6.200	0.228	0.244
e	1.270 (BSC)		0.050 (BSC)	
L	0.400	1.270	0.016	0.050
θ	0°	8°	0°	8°

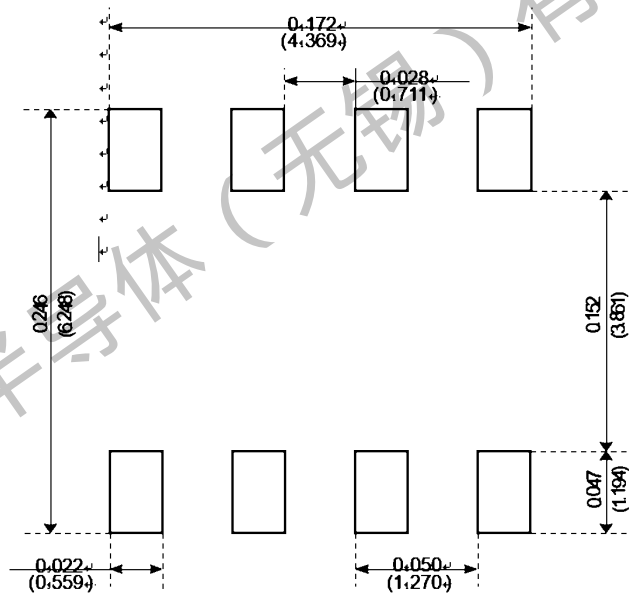

Recommended Minimum Pads

TM4606C

N+P-Channel Enhancement Mode Mosfet

SOP-8L Embossed Carrier Tape

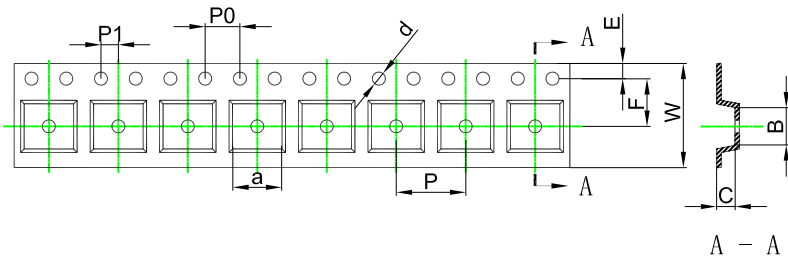

Packaging Description:

SOP-8L parts are shipped in tape. The carrier tape is made from a dissipative (carbon filled) polycarbonate resin. The cover tape is a multilayer film (Heat Activated Adhesive in nature) primarily composed of polyester film, adhesive layer, sealant, and anti-static sprayed agent. These reeled parts in standard option are shipped with 2,500 units per 13" or 33cm diameter reel. The reels are clear in color and is made of polystyrene plastic (anti-static coated).

ALL DIM IN mm

Dimensions are in millimeter										
Pkg type	a	B	C	d	E	F	P0	P	P1	W
SOP-8L	6.40	5.40	2.10	Ø1.50	1.75	5.50	4.00	8.00	2.00	12.00

SOP-8L Tape Leader and Trailer

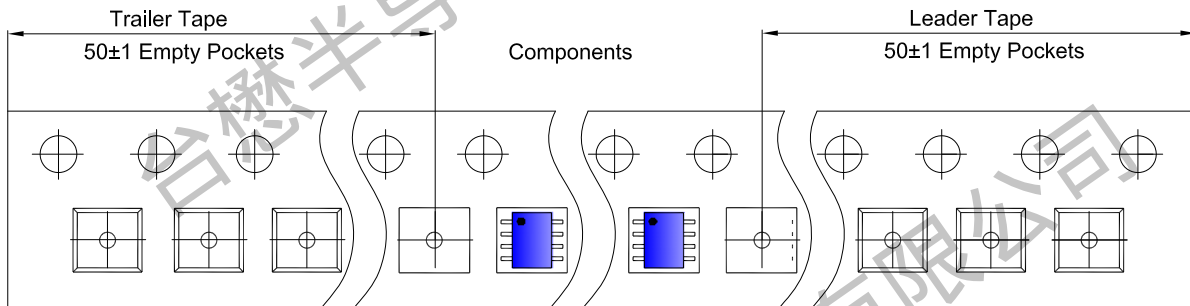

SOP-8L Reel

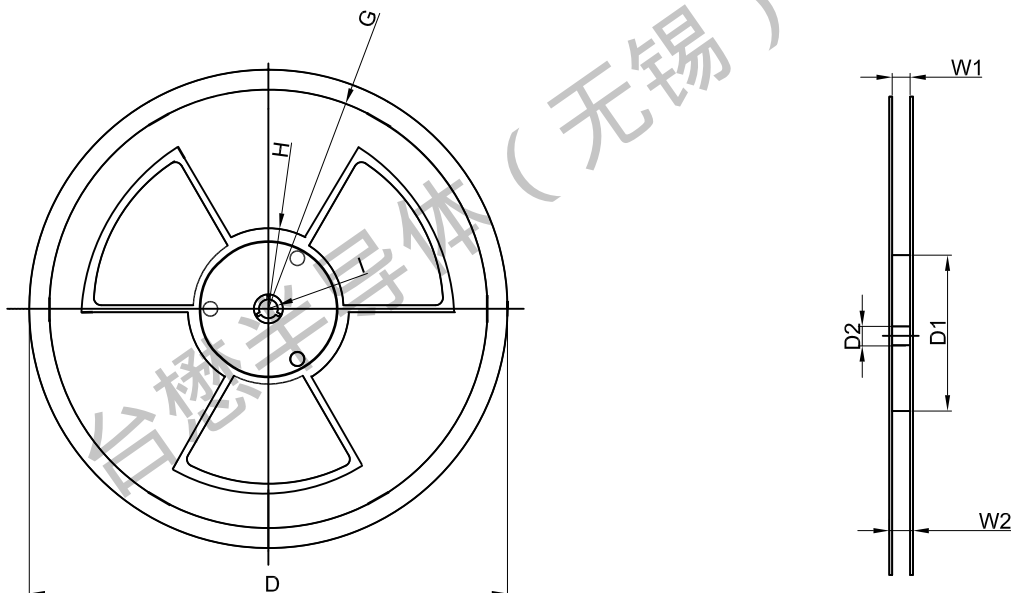

Dimensions are in millimeter								
Reel Option	D	D1	D2	G	H	I	W1	W2
13" Dia	Ø330.00	100.00	13.00	R135.00	R55.00	R6.50	12.00	14.00

REEL	Reel Size	Box	Box Size(mm)	Carton	Carton Size(mm)	G.W.(kg)
3,000 pcs	13 inch	6,000 pcs	370×355×52	48,000 pcs	400×360×368	



Important Notices and Disclaimers

- Tritech-MOS Technology Corp.reserves the right to change thisdocument, its products, and specifications at any time without prior notice.
- Before final design, purchase, or use, customers should obtain and confirm the latest product information and specifications.
- Tritech-MOS Technology Corp. makes no warranties, representations or warranties regarding the suitability of its products for any specific purpose, and Tritech-MOS Technology Corp. does not assume any responsibility for application assistance or customer product design.
- Tritech-MOS Technology Corp. does not guarantee or assume any responsibility for the purchase or use of any unexpected or unauthorized products.
- Any intellectual property rights of Tritech-MOS Technology Corp. are not licensed through implicate or other means.
- Products of Tritech-MOS Technology Corp. are not included as critical components in life support equipment or systems without explicit written approval from Tritech-MOS Technology Corp.

Revision history:

Date	Rev	Description	Page
2024.05.14	24.05	Original	