



TM30P15NF

P-Channel Enhancement Mosfet

General Description

- Low $R_{DS(ON)}$
- RoHS and Halogen-Free Compliant

Applications

- Load switch
- PWM

General Features

$V_{DS} = -150V$ $I_D = -30A$

$R_{DS(ON)} = 78m\Omega$ (typ.) @ $V_{GS} = -10V$

100% UIS Tested
100% R_g Tested

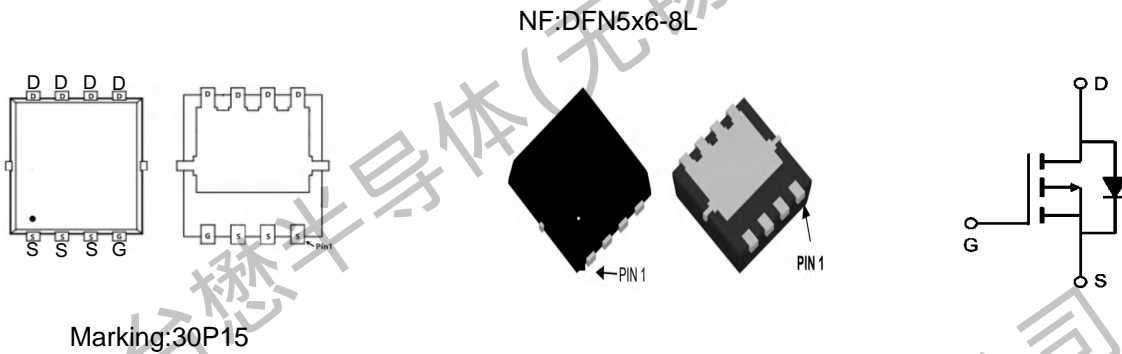

Absolute Maximum Ratings ($T_c = 25^\circ C$ unless otherwise noted)

Symbol	Parameter	Rating	Units
V_{DS}	Drain-Source Voltage	-150	V
V_{GS}	Gate-Source Voltage	± 20	V
$I_D @ T_c = 25^\circ C$	Continuous Drain Current, $-V_{GS} @ -10V$	-30	A
$I_D @ T_c = 100^\circ C$	Continuous Drain Current, $-V_{GS} @ -10V$	-16	A
I_{DM}	Pulsed Drain Current	-100	A
EAS	Single Pulse Avalanche Energy	380	mJ
$P_D @ T_c = 25^\circ C$	Total Power Dissipation	23	W
T_{STG}	Storage Temperature Range	-55 to 175	$^\circ C$
T_J	Operating Junction Temperature Range	-55 to 175	$^\circ C$

Thermal Data

Symbol	Parameter	Typ.	Max.	Unit
$R_{\theta JA}$	Thermal Resistance Junction-Ambient	---	---	$^\circ C/W$
$R_{\theta JC}$	Thermal Resistance Junction-Case	---	2.2	$^\circ C/W$

TM30P15NF

P-Channel Enhancement Mosfet

Electrical Characteristics (T_J=25 °C, unless otherwise noted)

Symbol	Parameter	Conditions	Min.	Typ.	Max.	Unit
BV _{DSS}	Drain-Source Breakdown Voltage	V _{GS} =0V, I _D =-250uA	-150	---	---	V
ΔBV _{DSS} /ΔT _J	BV _{DSS} Temperature Coefficient	Reference to 25°C, I _D =-1mA	---	---	---	V/°C
R _{DS(ON)}	Static Drain-Source On-Resistance	V _{GS} =-10V, I _D =-12A	---	78	105	mΩ
		V _{GS} =-4.5V, I _D =-8A	---	80	109	
V _{GS(th)}	Gate Threshold Voltage	V _{GS} =V _{DS} , I _D =-250uA	-2	-3	-4	V
ΔV _{GS(th)}	V _{GS(th)} Temperature Coefficient		---	---	---	mV/°C
I _{DSS}	Drain-Source Leakage Current	V _{DS} =-150V, V _{GS} =0V, T _J =25°C	---	---	-1	uA
		V _{DS} =-150V, V _{GS} =0V, T _J =100°C	---	---	-5	
I _{GSS}	Gate-Source Leakage Current	V _{GS} =±20V, V _{DS} =0V	---	---	±100	nA
g _{fs}	Forward Transconductance	V _{DS} =-10V, I _D =-3	---	11	---	S
R _g	Gate Resistance	V _{DS} =0V, V _{GS} =0V, f=1MHz	---	0.8	---	Ω
Q _g	Total Gate Charge	V _{DS} =-75V, V _{GS} =-10V, I _D =-3A	---	142	---	nC
Q _{gs}	Gate-Source Charge		---	26.7	---	
Q _{gd}	Gate-Drain Charge		---	50	---	
T _{d(on)}	Turn-On Delay Time	V _{GS} =-10V, V _{DS} =-75V, I _D =-3A, R _{GEN} =3Ω	---	36.2	---	ns
T _r	Rise Time		---	136	---	
T _{d(off)}	Turn-Off Delay Time		---	85	---	
T _f	Fall Time		---	60	---	
C _{iss}	Input Capacitance	V _{DS} =-75V, V _{GS} =0V, f=1MHz	---	8178	---	pF
C _{oss}	Output Capacitance		---	127	---	
C _{rss}	Reverse Transfer Capacitance		---	114	---	

Diode Characteristics

Symbol	Parameter	Conditions	Min.	Typ.	Max.	Unit
I _s	Continuous Source Current	V _G =V _D =0V, Force Current	---	---	-30	A
V _{SD}	Diode Forward Voltage	V _{GS} =0V, I _s =-3A, T _J =25°C	---	---	-1.2	V
t _{rr}	Reverse Recovery Time	I _F =-3A, di/dt=100A/μs,	---	88	---	nS
Q _{rr}	Reverse Recovery Charge	T _J =25°C	---	182	---	nC



TM30P15NF

P-Channel Enhancement Mosfet

Typical Electrical And Thermal Characteristics (Curves)

Figure 1. Output Characteristics

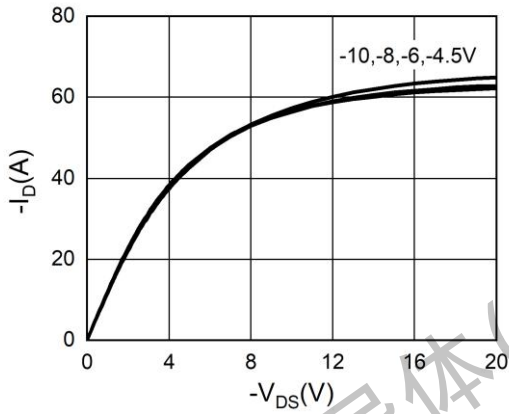

Figure 2. Transfer Characteristics

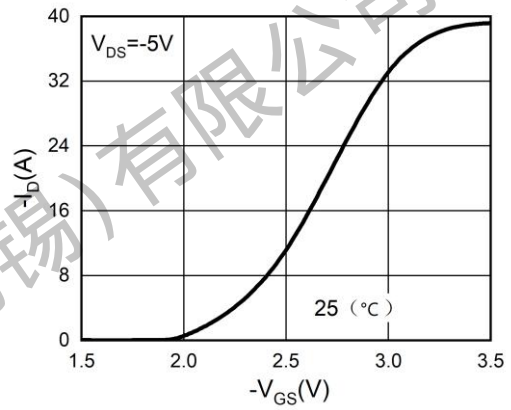

Figure 3. Power Dissipation

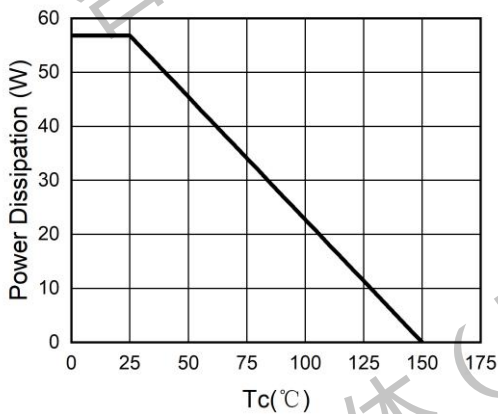

Figure 4. Drain Current

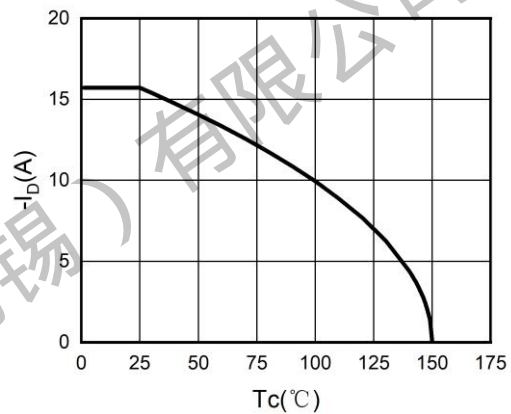

Figure 5. BV_{DSS} vs Junction Temperature

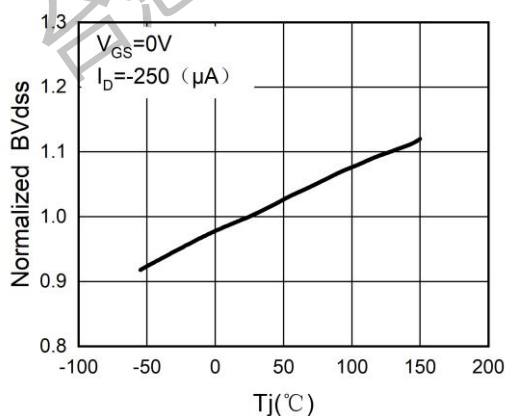
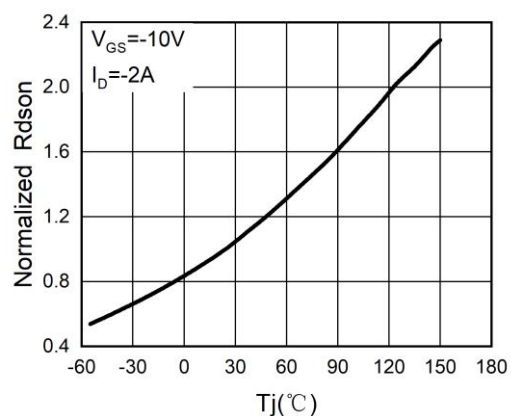

Figure 6. R_{DS(ON)} vs Junction Temperature





TM30P15NF

P-Channel Enhancement Mosfet

Typical Electrical And Thermal Characteristics (Curves)

Figure 7. Gate Charge Waveforms

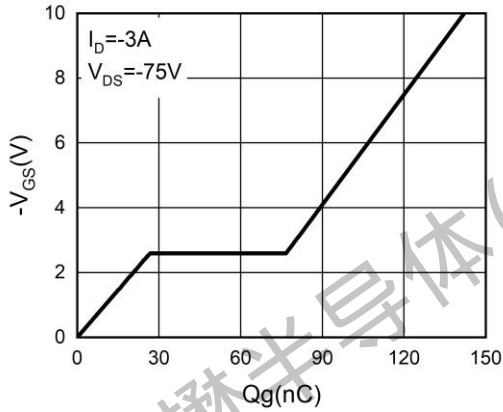

Figure 8. Capacitance

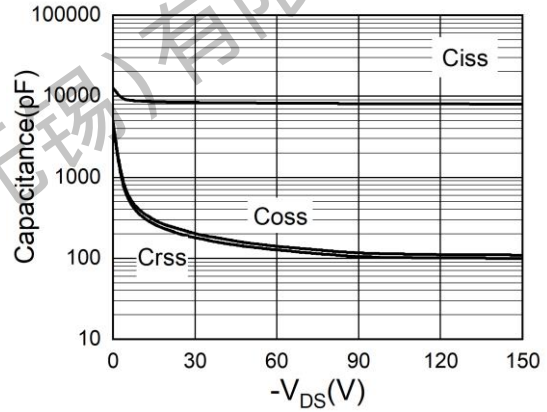

Figure 9. Body-Diode Characteristics

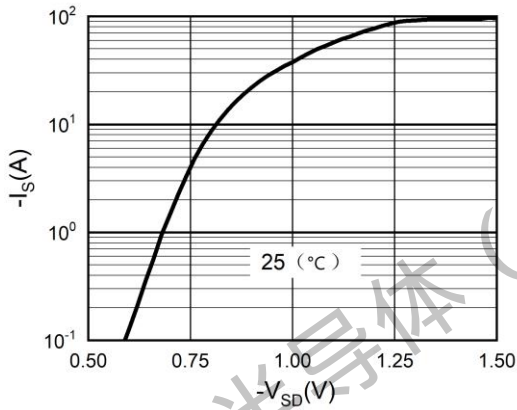
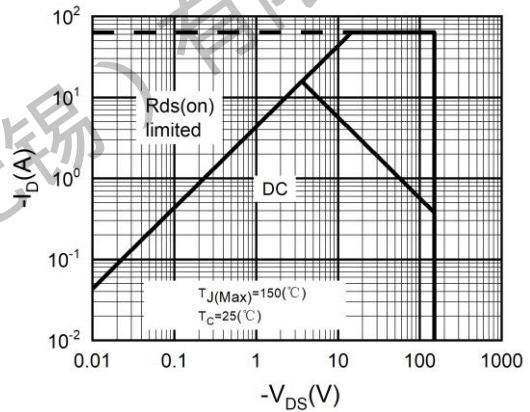

Figure 10. Maximum Safe Operating Area



TM30P15NF

P-Channel Enhancement Mosfet

Package Mechanical Data:DFN5x6-8L

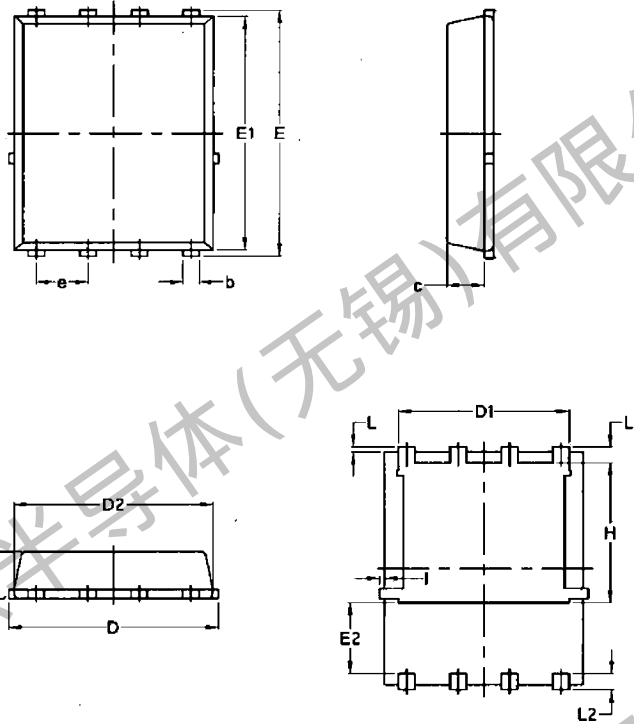

Symbol	Common			
	mm		Inch	
	Min	Max	Min	Max
A	1.03	1.17	0.0406	0.0461
b	0.34	0.48	0.0134	0.0189
c	0.824	0.0970	0.0324	0.082
D	4.80	5.40	0.1890	0.2126
D1	4.11	4.31	0.1618	0.1697
D2	4.80	5.00	0.1890	0.1969
E	5.95	6.15	0.2343	0.2421
E1	5.65	5.85	0.2224	0.2303
E2	1.60	/	0.0630	/
e	1.27 BSC		0.05 BSC	
L	0.05	0.25	0.0020	0.0098
L1	0.38	0.50	0.0150	0.0197
L2	0.38	0.50	0.0150	0.0197
H	3.30	3.50	0.1299	0.1378
I	/	0.18	/	0.0070

TM30P15NF

P-Channel Enhancement Mosfet

PDFN5x6-8L Embossed Carrier Tape

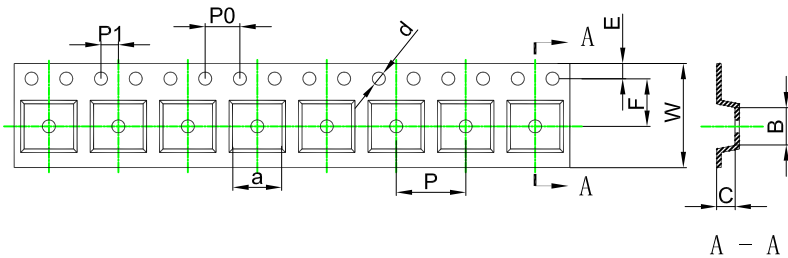

Packaging Description:
SOP-8L parts are shipped in tape. The carrier tape is made from a dissipative (carbon filled) polycarbonate resin. The cover tape is a multilayer film (Heat Activated Adhesive in nature) primarily composed of polyester film, adhesive layer, sealant, and anti-static sprayed agent. These reeled parts in standard option are shipped with 2,500 units per 13" or 33cm diameter reel. The reels are clear in color and is made of polystyrene plastic (anti-static coated).
ALL DIM IN mm

Dimensions are in millimeter										
Pkg type	a	B	C	d	E	F	P0	P	P1	W
PDFN5x6-8L	6.40	5.40	2.10	Ø1.50	1.75	5.50	4.00	8.00	2.00	12.00

PDFN5x6-8L Tape Leader and Trailer

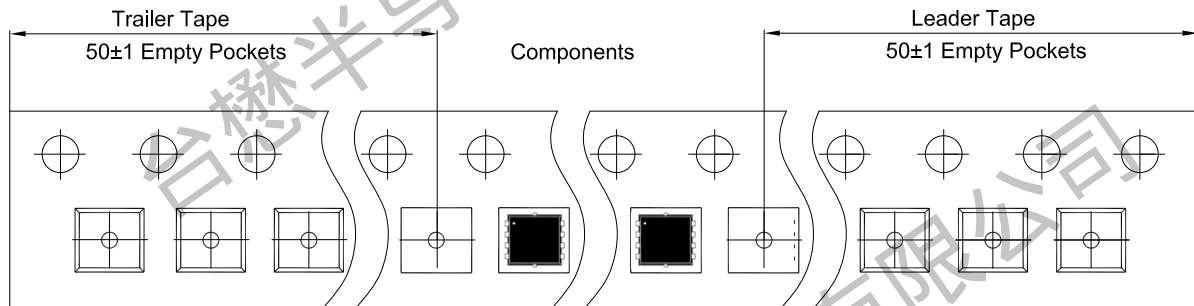

PDFN5x6-8L Reel

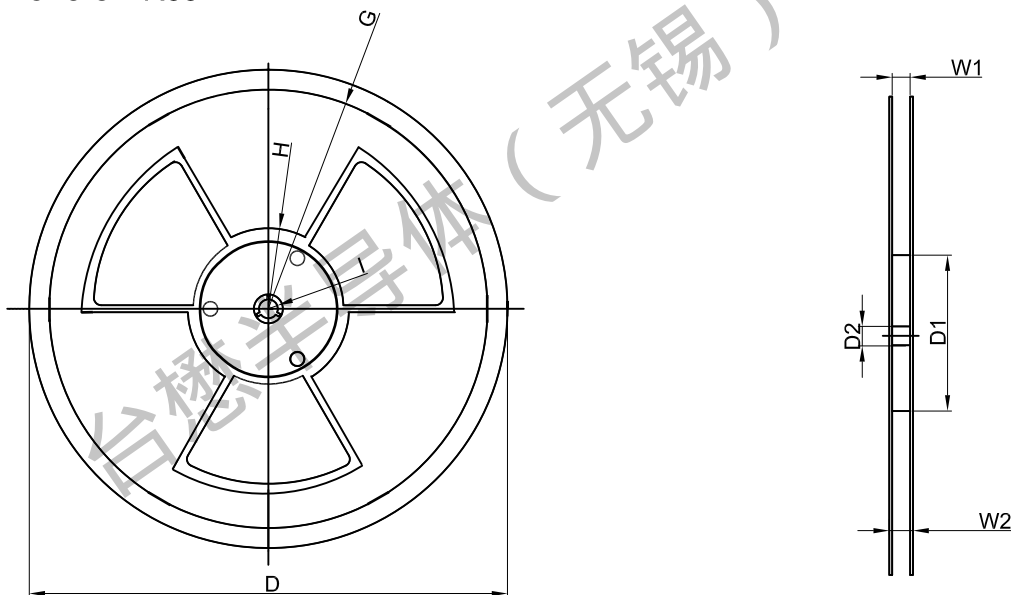

Dimensions are in millimeter								
Reel Option	D	D1	D2	G	H	I	W1	W2
13"Dia	Ø330.00	100.00	13.00	R135.00	R55.00	R6.50	12.00	14.00

REEL	Reel Size	Box	Box Size(mm)	Carton	Carton Size(mm)	G.W.(kg)
5,000 pcs	13 inch	10,000 pcs	370×355×52	50,000 pcs	400×360×368	

Important Notices and Disclaimers

- Tritech-MOS Technology Corp. reserves the right to change this document, its products, and specifications at any time without prior notice.
- Before final design, purchase, or use, customers should obtain and confirm the latest product information and specifications.
- Tritech-MOS Technology Corp. makes no warranties, representations or warranties regarding the suitability of its products for any specific purpose, and Tritech-MOS Technology Corp. does not assume any responsibility for application assistance or customer product design.
- Tritech-MOS Technology Corp. does not guarantee or assume any responsibility for the purchase or use of any unexpected or unauthorized products.
- Any intellectual property rights of Tritech-MOS Technology Corp. are not licensed through implicate or other means.
- Products of Tritech-MOS Technology Corp. are not included as critical components in life support equipment or systems without explicit written approval from Tritech-MOS Technology Corp.

Revision history:

Date	Rev	Description	Page
2023.09.19	23.09	Original	