

# TM20P04S

# P-Channel Enhancement Mosfet

<p><b>General Description</b></p> <ul style="list-style-type: none"> <li>• Low <math>R_{DS(ON)}</math></li> <li>• RoHS and Halogen-Free Compliant</li> </ul> <p><b>Applications</b></p> <ul style="list-style-type: none"> <li>• Load switch</li> <li>• PWM</li> </ul>	<p><b>General Features</b></p> <p><math>V_{DS} = -40V</math> <math>I_D = -20A</math>  <math>R_{DS(ON)} = 11 m\Omega @ V_{GS} = -10V</math></p> <p>100% UIS Tested          100% <math>R_g</math> Tested</p> 
--	---

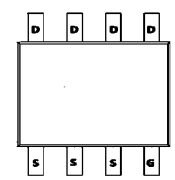

PIN1

Marking: 20P04

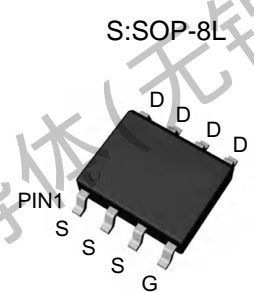

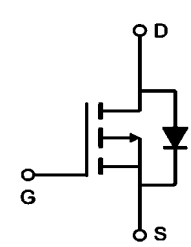

**Absolute Maximum Ratings** ( $T_A = 25^\circ C$  Unless Otherwise Noted)

Symbol	Parameter	Rating	Units
$V_{DS}$	Drain-Source Voltage	-40	V
$V_{GS}$	Gate-Source Voltage	$\pm 20$	V
$I_D @ T_A = 25^\circ C$	Continuous Drain Current, $V_{GS} @ 10V^1$	-20	A
$I_D @ T_A = 70^\circ C$	Continuous Drain Current, $V_{GS} @ 10V^1$	-14	A
$I_{DM}$	Pulsed Drain Current <sup>2</sup>	-68	A
$P_D$	Total Power Dissipation <sup>4</sup>	4.2	W
$T_{STG}$	Storage Temperature Range	-55 to 175	$^\circ C$
$T_J$	Operating Junction Temperature Range	-55 to 175	$^\circ C$

**Thermal Data**

Symbol	Parameter	Typ.	Max.	Unit
$R_{\theta JA}$	Thermal Resistance Junction-ambient <sup>1</sup>	---	80	$^\circ C/W$
$R_{\theta JC}$	Thermal Resistance Junction-Case <sup>1</sup>	---	25	$^\circ C/W$



# TM20P04S

# P-Channel Enhancement Mosfet

Electrical Characteristics: ( $T_c=25^\circ\text{C}$  unless otherwise noted)

Symbol	Parameter	Conditions	Min	Typ	Max	Units
<b>Off Characteristics</b>						
$BV_{DSS}$	Drain-Source Breakdown Voltage	$V_{GS}=0V, I_D=250\ \mu\text{A}$	-40	---	---	V
$I_{DSS}$	Zero Gate Voltage Drain Current	$V_{GS}=0V, V_{DS}=-40V, T_J=25^\circ\text{C}$	---	---	-1	$\mu\text{A}$
$I_{GSS}$	Gate-Source Leakage Current	$V_{GS}=\pm 20V, V_{DS}=0A$	---	---	$\pm 100$	nA
<b>On Characteristics</b>						
$V_{GS(th)}$	GATE-Source Threshold Voltage	$V_{GS}=V_{DS}, I_D=250\ \mu\text{A}$	-1.4	-1.75	-2.0	V
$R_{DS(on)}$	Drain-Source On Resistance <sup>2</sup>	$V_{GS}=-10V, I_D=-10A$	---	11	15	m $\Omega$
		$V_{GS}=-4.5V, I_D=-8A$	---	16	22	
$G_{FS}$	Forward Transconductance	$V_{DS}=-10V, I_D=-10A$	---	13	---	S
<b>Dynamic Characteristics</b>						
$C_{iss}$	Input Capacitance	$V_{DS}=-25V, V_{GS}=0V, f=1\text{MHz}$	---	1957	4000	pF
$C_{oss}$	Output Capacitance		---	240	360	
$C_{rss}$	Reverse Transfer Capacitance		---	137	200	
<b>Switching Characteristics</b>						
$t_{d(on)}$	Turn-On Delay Time <sup>2,3</sup>	$V_{DS}=-20V, V_{GS}=-10V$ $I_D=-1A, R_{GEN}=6\ \Omega$	---	23	40	ns
$t_r$	Rise Time <sup>2,3</sup>		---	10	20	ns
$t_{d(off)}$	Turn-Off Delay Time <sup>2,3</sup>		---	135	250	ns
$t_f$	Fall Time <sup>2,3</sup>		---	46	90	ns
$Q_g$	Total Gate Charge <sup>2,3</sup>	$V_{DS}=-32V, V_{GS}=-4.5V,$ $I_D=-10A$	---	22.2	40	nC
$Q_{gs}$	Gate-Source Charge <sup>2,3</sup>		---	8.2	16	nC
$Q_{gd}$	Gate-Drain "Miller" Charge <sup>2,3</sup>		---	8.8	16	nC
<b>Drain-Source Diode Characteristics</b>						
$V_{SD}$	Source-Drain Diode Forward Voltage <sup>2</sup>	$V_{GS}=0V, I_S=-1A, T_J=25^\circ\text{C}$	---	---	-1	V
$I_S$	Continuous Source Current	$V_G=V_D=0V, \text{Force Current}$	---	---	-20	A
$I_{SM}$	Pulsed Source Current		---	---	-20	A

**Notes:**

1. Repetitive Rating : Pulsed width limited by maximum junction temperature.
2. The data tested by pulsed , pulse width  $\leq 300\mu\text{s}$  , duty cycle  $\leq 2\%$ .
3. Essentially independent of operating temperature.



**TM20P04S**

**P-Channel Enhancement Mosfet**

Typical Characteristics: ( $T_C=25^\circ\text{C}$  unless otherwise noted)

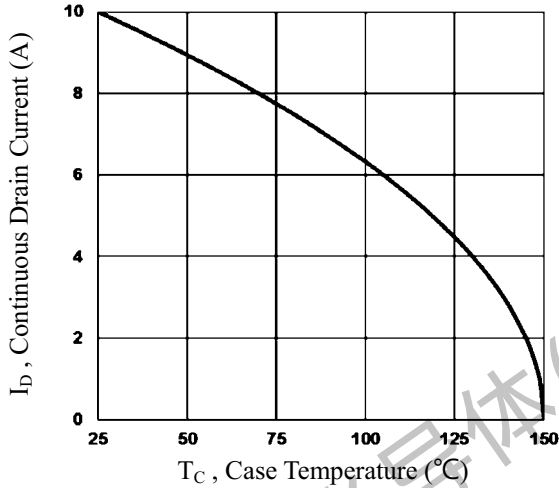

Fig.1 Continuous Drain Current vs.  $T_C$

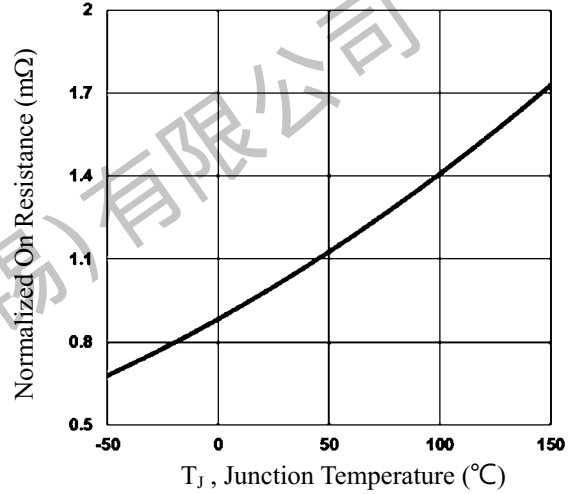

Fig.2 Normalized  $R_{DS(on)}$  vs.  $T_J$

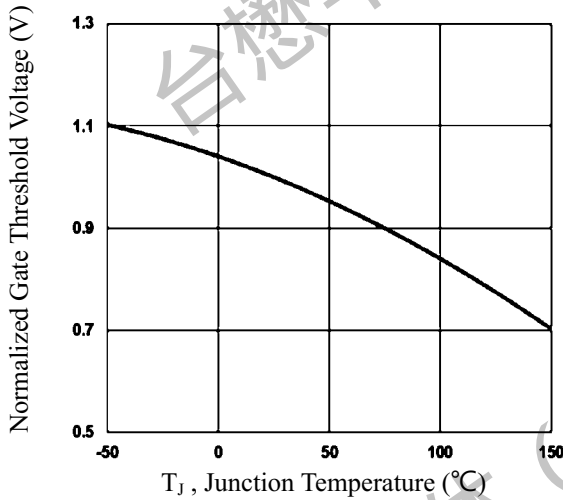

Fig.3 Normalized  $V_{th}$  vs.  $T_J$

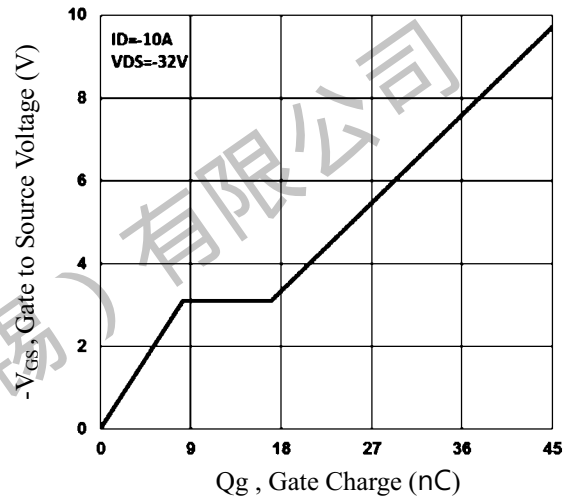

Fig.4 Gate Charge Waveform

TM20P04S

P-Channel Enhancement Mosfet

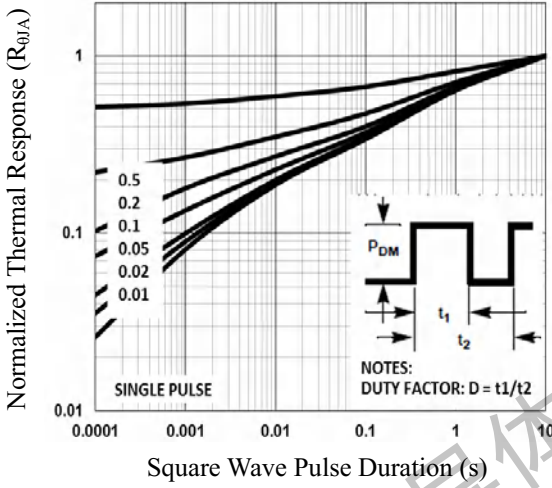

Fig.5 Normalized Transient Impedance

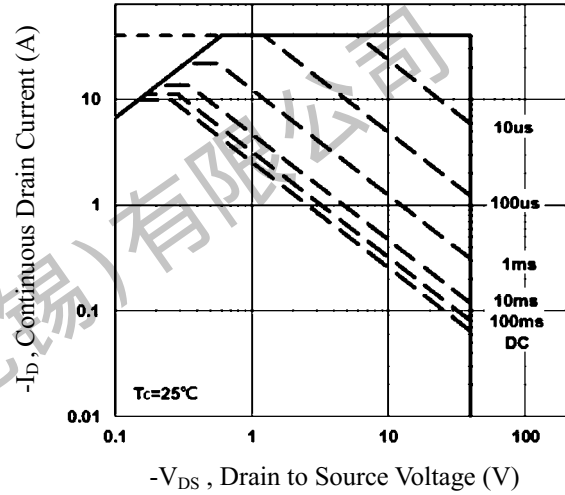

Fig.6 Maximum Safe Operation Area

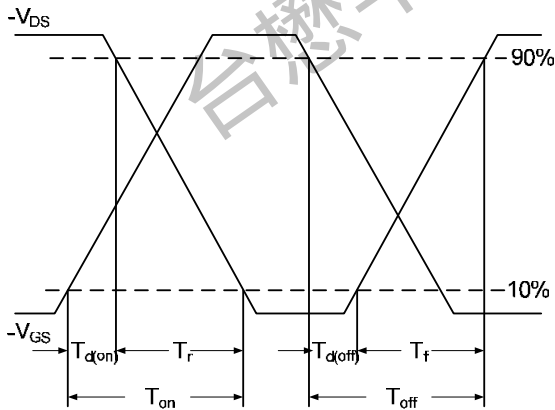

Fig.7 Switching Time Waveform

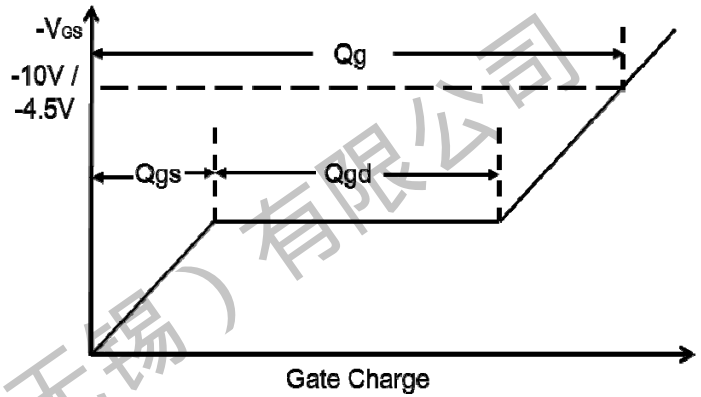
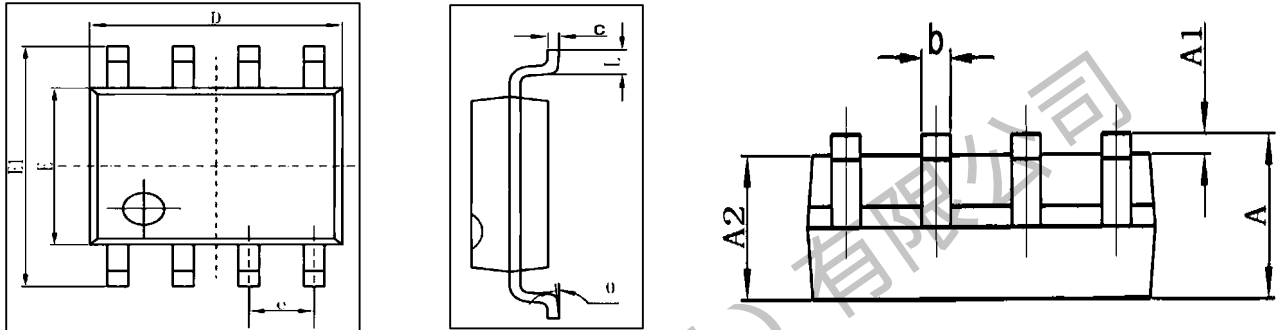

Fig.8 Gate Charge Waveform

TM20P04S

P-Channel Enhancement Mosfet

Package Mechanical Data:SOP-8L



Symbol	Dimensions In Millimeters		Dimensions In Inches	
	Min	Max	Min	Max
A	1.350	1.750	0.053	0.069
A1	0.100	0.250	0.004	0.010
A2	1.350	1.550	0.053	0.061
b	0.330	0.510	0.013	0.020
c	0.170	0.250	0.006	0.010
D	4.700	5.100	0.185	0.200
E	3.800	4.000	0.150	0.157
E1	5.800	6.200	0.228	0.244
e	1.270 (BSC)		0.050 (BSC)	
L	0.400	1.270	0.016	0.050
θ	0°	8°	0°	8°

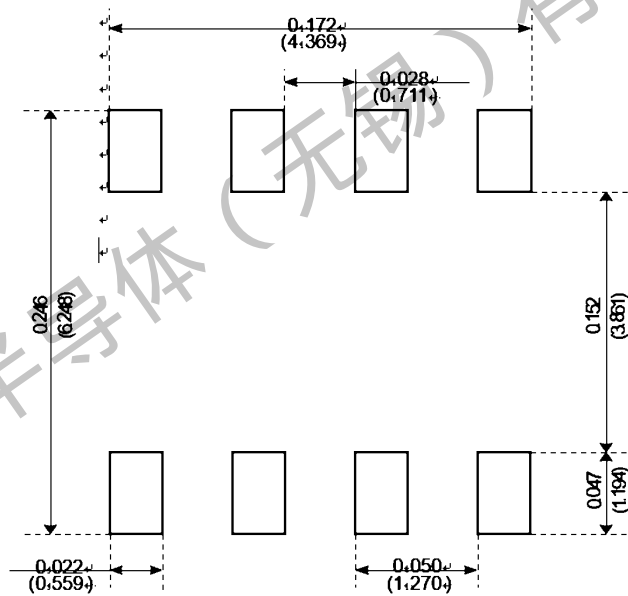

Recommended Minimum Pads

**TM20P04S**

**P-Channel Enhancement Mosfet**

**SOP-8L Embossed Carrier Tape**

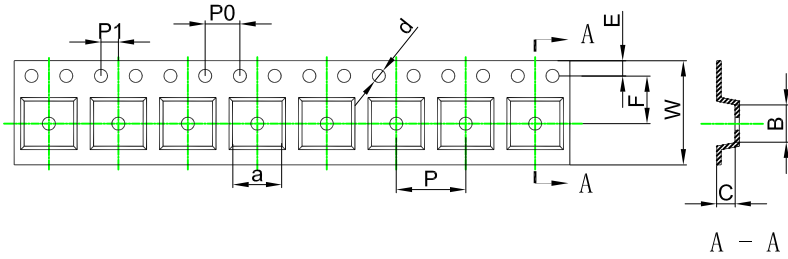

**Packaging Description:**  
SOP-8L parts are shipped in tape. The carrier tape is made from a dissipative (carbon filled) polycarbonate resin. The cover tape is a multilayer film (Heat Activated Adhesive in nature) primarily composed of polyester film, adhesive layer, sealant, and anti-static sprayed agent. These reeled parts in standard option are shipped with 2,500 units per 13" or 33cm diameter reel. The reels are clear in color and is made of polystyrene plastic (anti-static coated).  
**ALL DIM IN mm**

Dimensions are in millimeter										
Pkg type	a	B	C	d	E	F	P0	P	P1	W
SOP-8L	6.40	5.40	2.10	Ø1.50	1.75	5.50	4.00	8.00	2.00	12.00

**SOP-8L Tape Leader and Trailer**

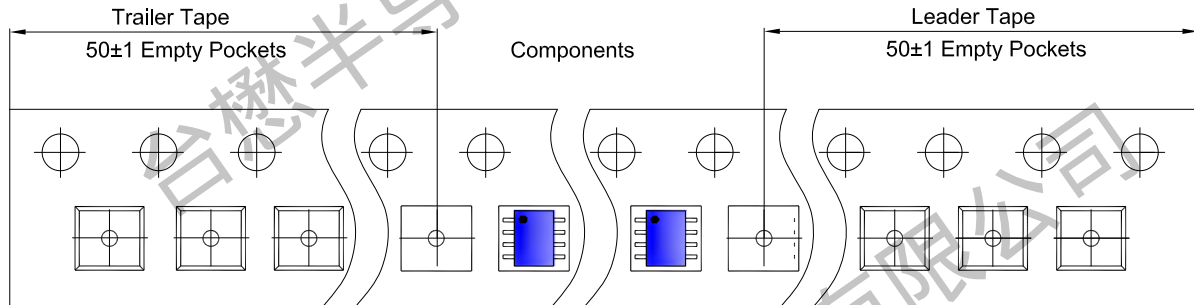

**SOP-8L Reel**

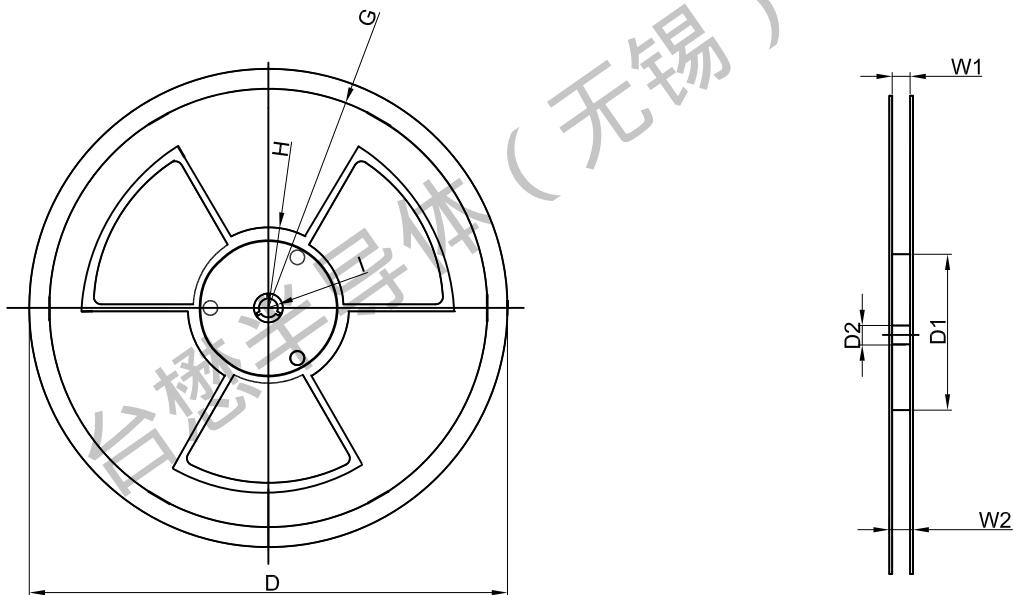

Dimensions are in millimeter								
Reel Option	D	D1	D2	G	H	I	W1	W2
13" Dia	Ø330.00	100.00	13.00	R135.00	R55.00	R6.50	12.00	14.00

REEL	Reel Size	Box	Box Size(mm)	Carton	Carton Size(mm)	G.W.(kg)
3,000 pcs	13 inch	6,000 pcs	370×355×52	48,000 pcs	400×360×368	

### Important Notices and Disclaimers

- Tritech-MOS Technology Corp. reserves the right to change this document, its products, and specifications at any time without prior notice.
- Before final design, purchase, or use, customers should obtain and confirm the latest product information and specifications.
- Tritech-MOS Technology Corp. makes no warranties, representations or warranties regarding the suitability of its products for any specific purpose, and Tritech-MOS Technology Corp. does not assume any responsibility for application assistance or customer product design.
- Tritech-MOS Technology Corp. does not guarantee or assume any responsibility for the purchase or use of any unexpected or unauthorized products.
- Any intellectual property rights of Tritech-MOS Technology Corp. are not licensed through implicate or other means.
- Products of Tritech-MOS Technology Corp. are not included as critical components in life support equipment or systems without explicit written approval from Tritech-MOS Technology Corp.

Revision history:

Date	Rev	Description	Page
2023.05.14	23.05	Original	