



TM100N04AD

N-Channel Enhancement Mosfet

<p>General Description</p> <ul style="list-style-type: none"> • Low $R_{DS(ON)}$ • RoHS and Halogen-Free Compliant <p>Applications</p> <ul style="list-style-type: none"> • Load switch • PWM 	<p>General Features</p> <p>$V_{DS} = 40V$ $I_D = 90A$</p> <p>$R_{DS(ON)} = 5.2 m\Omega$ (Typ.) @ $V_{GS} = 10V$</p> <p>100% UIS Tested 100% R_g Tested</p>
--	---

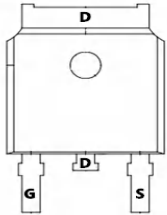
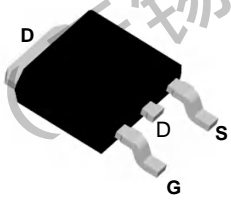
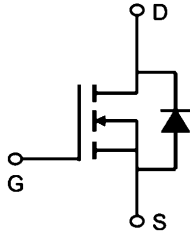

D:TO-252-3L

Marking: 100N04A

Absolute Maximum Ratings ($T_C = 25^\circ C$ Unless Otherwise Noted)

Symbol	Parameter	Rating	Units
V_{DS}	Drain-Source Voltage	40	V
V_{GS}	Gate-Source Voltage	± 20	V
$I_D @ T_C = 25^\circ C$	Continuous Drain Current, $V_{GS} @ 10V$	90	A
$I_D @ T_C = 100^\circ C$	Continuous Drain Current, $V_{GS} @ 10V$	59	A
I_{DM}	Pulsed Drain Current	333	A
EAS	Single Pulse Avalanche Energy	81	mJ
P_D	Total Power Dissipation	47	W
T_{STG}	Storage Temperature Range	-55 to 150	$^\circ C$
T_J	Operating Junction Temperature Range	-55 to 150	$^\circ C$

Thermal Data

Symbol	Parameter	Typ.	Max.	Unit
$R_{\theta JA}$	Thermal Resistance Junction-ambient	---	62	$^\circ C/W$
$R_{\theta JC}$	Thermal Resistance Junction-Case	---	6.6	$^\circ C/W$



TM100N04AD

N-Channel Enhancement Mosfet

Electrical Characteristics: (Tc=25°C unless otherwise noted)

Symbol	Parameter	Conditions	Min	Typ	Max	Units
Off Characteristics						
BV_{DSS}	Drain-Source Breakdown Voltage	V _{GS} =0V, I _D =250 μ A	40	---	---	V
I_{DSS}	Zero Gate Voltage Drain Current	V _{DS} =40V, V _{GS} =0V	---	---	1.0	μ A
I_{GSS}	Gate-Source Leakage Current	V _{GS} =± 20V, V _{DS} =0A	---	---	± 100	nA
On Characteristics						
V_{GS(th)}	GATE-Source Threshold Voltage	V _{GS} =V _{DS} , I _D =250 μ A	1.2	1.6	2.0	V
R_{DS(on)}	Drain-Source On Resistanc ²	V _{GS} =10V, I _D =30A	---	5.2	6.6	m Ω
		V _{GS} =4.5V, I _D =20A	---	6.7	9.8	m Ω
Dynamic Characteristics						
C_{iss}	Input Capacitance	V _{DS} =20V, V _{GS} =0V, f=1MHz	---	2180	---	pF
C_{oss}	Output Capacitance		---	188	---	
C_{rss}	Reverse Transfer Capacitance		---	160	---	
Switching Characteristics						
t_{d(on)}	Turn-On Delay Time	V _{DD} =20V, V _{GS} =10V, RG=3Ω, I _D =30A	---	10	---	ns
t_r	Rise Time		---	10	---	ns
t_{d(off)}	Turn-Off Delay Time		---	35	---	ns
t_f	Fall Time		---	7	---	ns
Q_g	Total Gate Charge	V _{GS} =10V, V _{DS} =20V, I _D =30A	---	35	---	nC
Q_{gs}	Gate-Source Charge		---	5	---	nC
Q_{gd}	Gate-Drain "Miller" Charge		---	6	---	nC
Drain-Source Diode Characteristics						
I_S	Continuous Source Current ^{1, 4}	V _G =V _D =0V,	---	---	90	A
I_{SM}	Pulsed Source Current ^{2, 4}	Force Current	---	---	333	A
V_{SD}	Diode Forward Voltage ²	V _{GS} =0V, I _S =30A	---	---	1.2	V
T_{rr}	Reverse Recovery Time	I _F =20A, di/dt=100A/μs, T _J =25°C	---	22	---	ns
Q_{rr}	Reverse Recovery Charge		---	11	---	nC



TM100N04AD

N-Channel Enhancement Mosfet

Typical Characteristics:

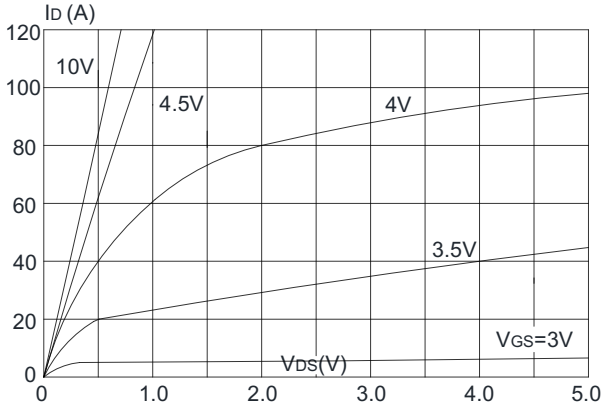

Figure 1: Output Characteristics

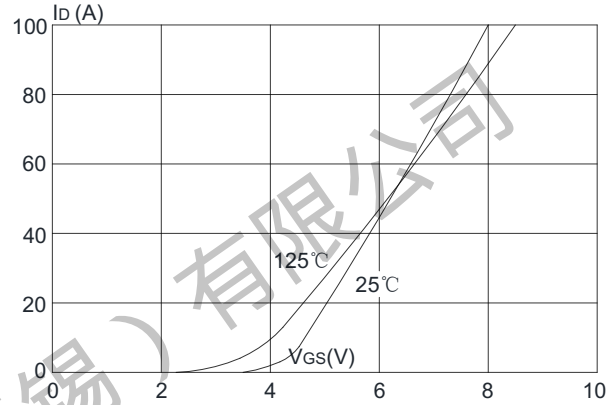

Figure 2: Typical Transfer Characteristics

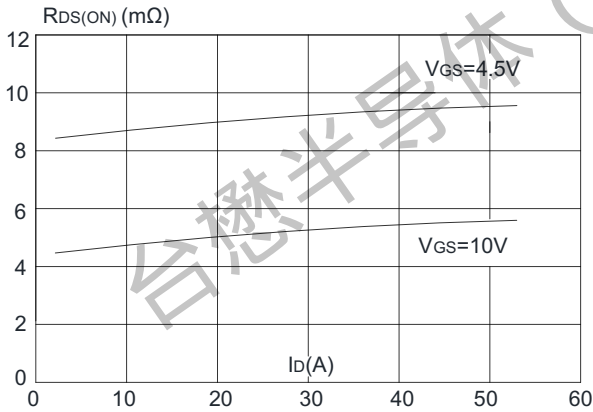

Figure 3: On-resistance vs. Drain Current

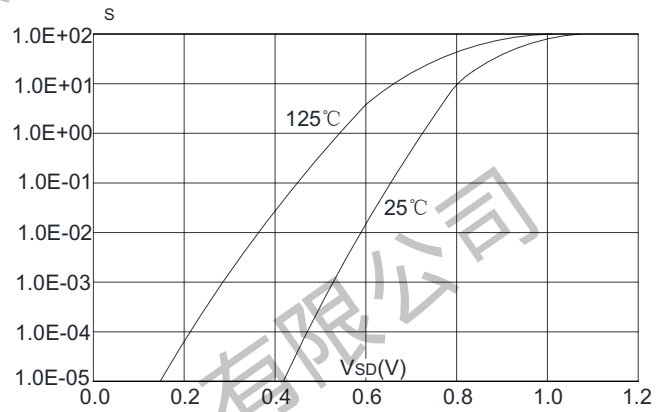

Figure 4: Body Diode Characteristics

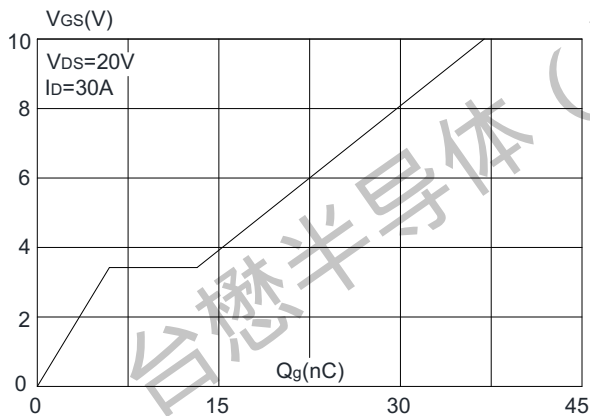

Figure 5: Gate Charge Characteristics

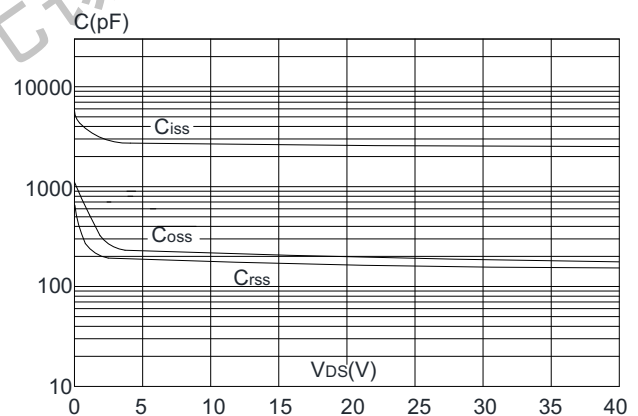

Figure 6: Capacitance Characteristics



TM100N04AD

N-Channel Enhancement Mosfet

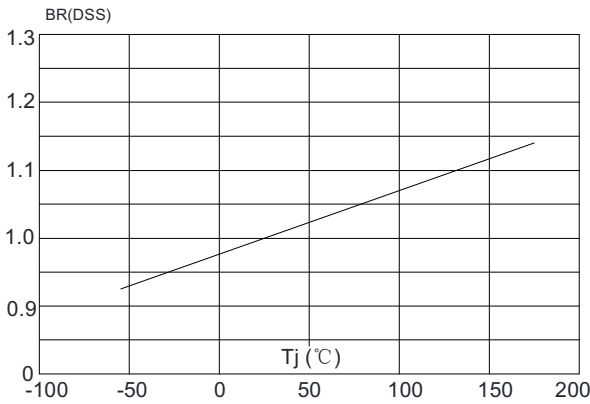

Figure 7: Normalized Breakdown Voltage vs. Junction Temperature

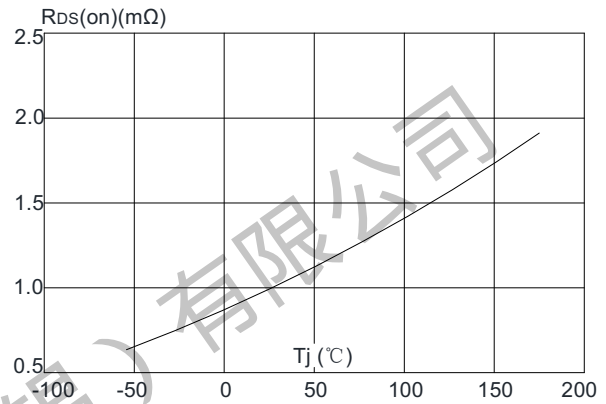

Figure 8: Normalized on Resistance vs. Junction Temperature

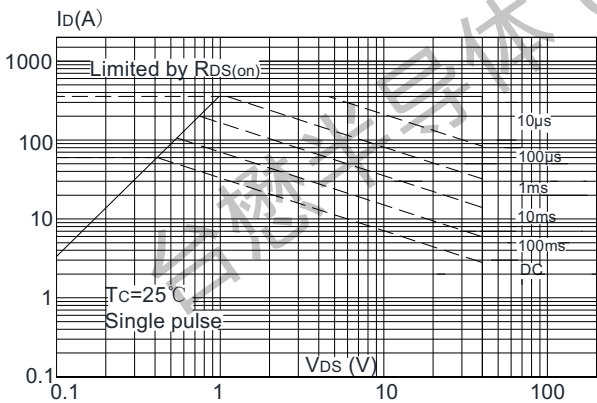

Figure 9: Maximum Safe Operating Area

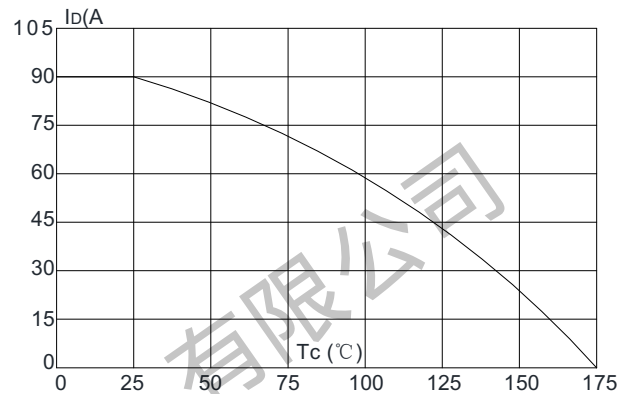

Figure 10: Maximum Continuous Drain Current vs. Case Temperature

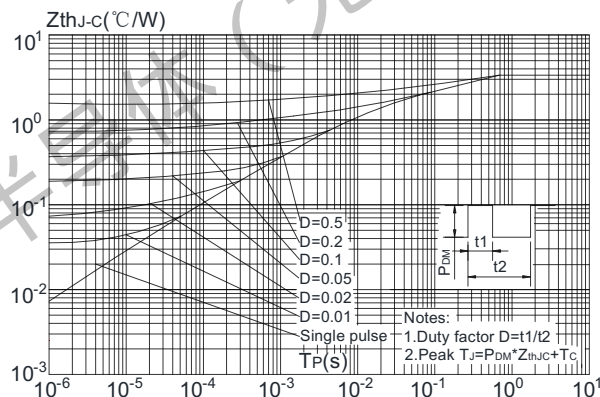

Figure.11: Maximum Effective Transient Thermal Impedance, Junction-to-Case



TM100N04AD

N-Channel Enhancement Mosfet

Package Mechanical Data: TO-252-3L

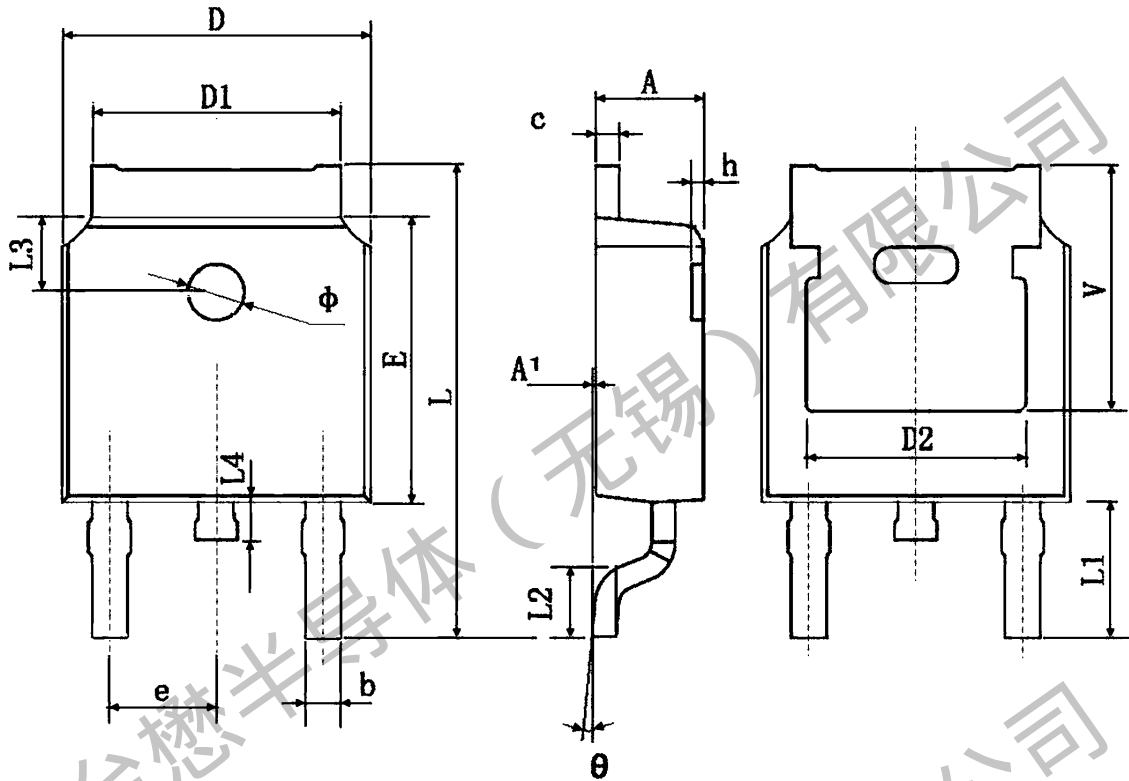

Symbol	Dimensions In Millimeters		Dimensions In Inches	
	Min.	Max.	Min.	Max.
A	2.200	2.400	0.087	0.094
A1	0.000	0.127	0.000	0.005
b	0.660	0.860	0.026	0.034
c	0.460	0.580	0.018	0.023
D	6.500	6.700	0.256	0.264
D1	5.100	5.460	0.201	0.215
D2	4.830 TYP.		0.190 TYP.	
E	6.000	6.200	0.236	0.244
e	2.186	2.386	0.086	0.094
L	9.800	10.400	0.386	0.409
L1	2.900 TYP.		0.114 TYP.	
L2	1.400	1.700	0.055	0.067
L3	1.600 TYP.		0.063 TYP.	
L4	0.600	1.000	0.024	0.039
φ	1.100	1.300	0.043	0.051
θ	0°	8°	0°	8°
h	0.000	0.300	0.000	0.012
V	5.350 TYP.		0.211 TYP.	



TM100N04AD

N-Channel Enhancement Mosfet

TO-252-3L Embossed Carrier Tape

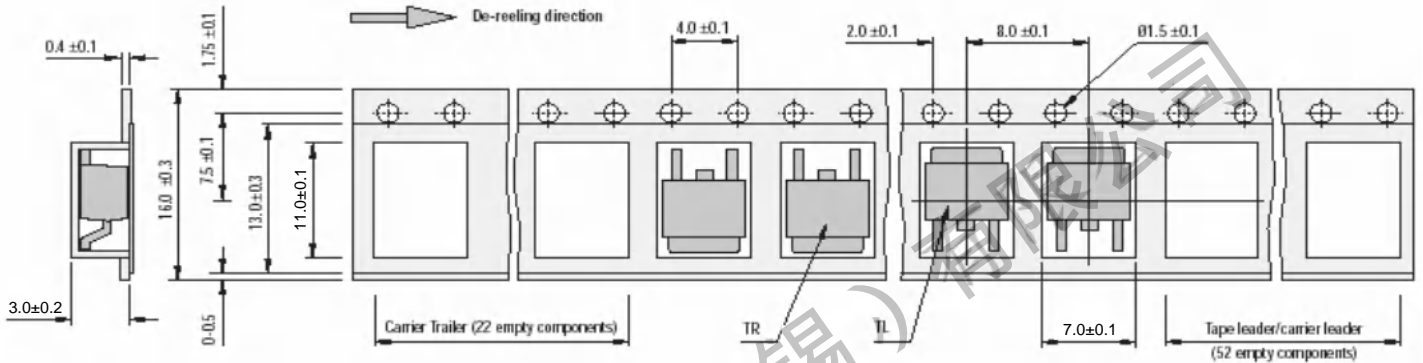

TO-252-3L Reel

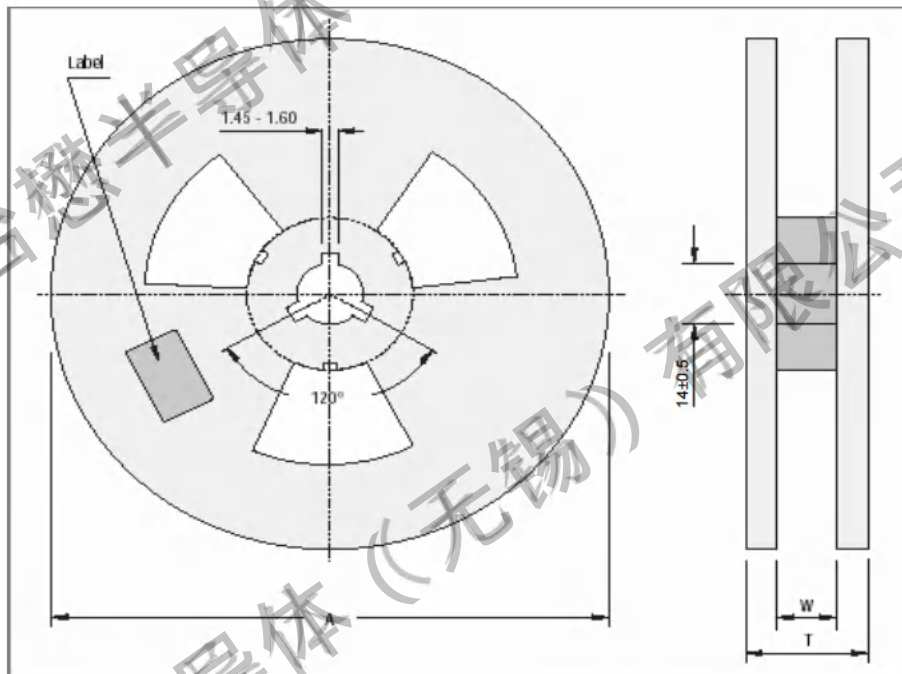

All Dimensions are in mm

Reel Specifications				
Package	Tape Width	Reel Dia. A - Max	Inside Thickness W	Reel Thickness T - max
TO-252-3L	16	330	18.0 ± 1.5	20

Packaging Information

REEL	Reel Size	Box	Box Size(mm)	Carton	Carton Size(mm)	G.W.(kg)
2,500 pcs	13 inch	5,000 pcs	355×370×50	25,000 pcs	380×275×380	

Important Notices and Disclaimers

- Tritech-MOS Technology Corp.reserves the right to change thisdocument, its products, and specifications at any time without prior notice.
- Before final design, purchase, or use, customers should obtain and confirm the latest product information and specifications.
- Tritech-MOS Technology Corp. makes no warranties, representations or warranties regarding the suitability of its products for any specific purpose, and Tritech-MOS Technology Corp. does not assume any responsibility for application assistance or customer product design.
- Tritech-MOS Technology Corp. does not guarantee or assume any responsibility for the purchase or use of any unexpected or unauthorized products.
- Any intellectual property rights of Tritech-MOS Technology Corp. are not licensed through implicate or other means.
- Products of Tritech-MOS Technology Corp. are not included as critical components in life support equipment or systems without explicit written approval from Tritech-MOS Technology Corp.

Revision history:

Date	Rev	Description	Page
2023.05.28	23.05	Original	