



TM06N03HMI

N-Channel Enhancement Mosfet

General Description

- Low $R_{DS(ON)}$
- RoHS and Halogen-Free Compliant

Applications

- Load switch
- PWM

General Features

$V_{DS} = 30V$ $I_D = 6.0A$

$R_{DS(ON)} = 20m\Omega$ (Typ.) @ $V_{GS} = 10V$

100% UIS Tested
100% R_g Tested



MI:SOT-23-3L

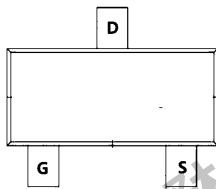

Marking: 3404

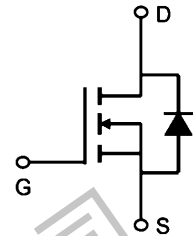
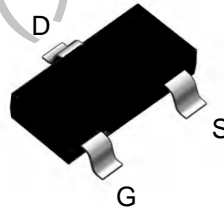

Absolute Maximum Ratings ($T_C = 25^\circ C$ unless otherwise noted)

Symbol	Parameter	Rating	Units
V_{DS}	Drain-Source Voltage	30	V
V_{GS}	Gate-Source Voltage	± 20	V
$I_D @ T_A = 25^\circ C$	Continuous Drain Current, $V_{GS} @ 10V$	6.0	A
$I_D @ T_A = 70^\circ C$	Continuous Drain Current, $V_{GS} @ 10V$	4.5	A
I_{DM}	Pulsed Drain Current	23.4	A
$P_D @ T_A = 25^\circ C$	Total Power Dissipation	1.6	W
T_{STG}	Storage Temperature Range	-55 to 175	$^\circ C$
T_J	Operating Junction Temperature Range	-55 to 175	$^\circ C$

Thermal Data

Symbol	Parameter	Typ.	Max.	Unit
$R_{\theta JA}$	Thermal Resistance Junction-ambient	---	85	$^\circ C/W$
$R_{\theta JC}$	Thermal Resistance Junction-Case	---	---	$^\circ C/W$

TM06N03HMI
N-Channel Enhancement Mosfet
Electrical Characteristics ($T_J=25^{\circ}\text{C}$ unless otherwise specified)

Symbol	Parameter	Test Condition	Min.	Typ.	Max.	Units
Off Characteristic						
$V_{(BR)DSS}$	Drain-Source Breakdown Voltage	$V_{GS}=0V, I_D=250\mu A$	30	-	-	V
I_{DSS}	Zero Gate Voltage Drain Current	$V_{DS}=30V, V_{GS}=0V,$	-	-	1.0	μA
I_{GSS}	Gate to Body Leakage Current	$V_{DS}=0V, V_{GS}=\pm 20V$	-	-	± 100	nA
On Characteristics						
$V_{GS(th)}$	Gate Threshold Voltage	$V_{DS}=V_{GS}, I_D=250\mu A$	1.2	1.6	2.0	V
$R_{DS(on)}$	Static Drain-Source on-Resistance note2	$V_{GS}=10V, I_D=5.5A$	-	20	25	m Ω
		$V_{GS}=4.5V, I_D=4.5A$	-	28	40	
Dynamic Characteristics						
C_{iss}	Input Capacitance	$V_{DS}=15V, V_{GS}=0V,$ $f=1.0MHz$	-	490	-	pF
C_{oss}	Output Capacitance		-	79	-	pF
C_{rss}	Reverse Transfer Capacitance		-	61	-	pF
Q_g	Total Gate Charge	$V_{DS}=15V, I_D=5.8A,$ $V_{GS}=10V$	-	5.2	-	nC
Q_{gs}	Gate-Source Charge		-	0.9	-	nC
Q_{gd}	Gate-Drain("Miller") Charge		-	1.3	-	nC
Switching Characteristics						
$t_{d(on)}$	Turn-on Delay Time	$V_{DS}=15V,$ $I_D=3A, R_{GEN}=3\Omega,$ $V_{GS}=10V$	-	4.5	-	ns
t_r	Turn-on Rise Time		-	2.5	-	ns
$t_{d(off)}$	Turn-off Delay Time		-	14.5	-	ns
t_f	Turn-off Fall Time		-	3.5	-	ns
Drain-Source Diode Characteristics and Maximum Ratings						
I_S	Maximum Continuous Drain to Source Diode Forward Current		-	-	6.0	A
I_{SM}	Maximum Pulsed Drain to Source Diode Forward Current		-	-	23.2	A
V_{SD}	Drain to Source Diode Forward Voltage	$V_{GS}=0V, I_S=5.8A$	-	-	1.2	V

TM06N03HMI

N-Channel Enhancement Mosfet

Figure 1: Output Characteristics

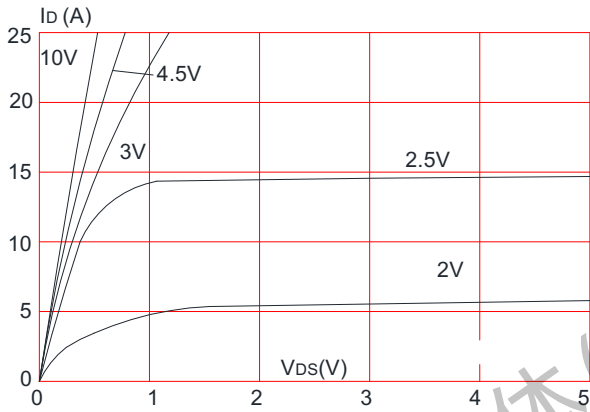

Figure 2: Typical Transfer Characteristics

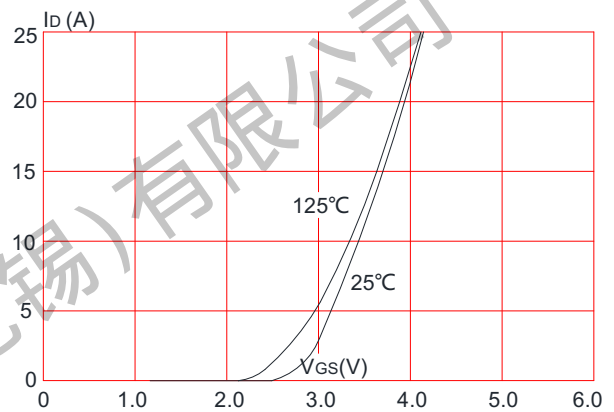

Figure 3: On-resistance vs. Drain Current

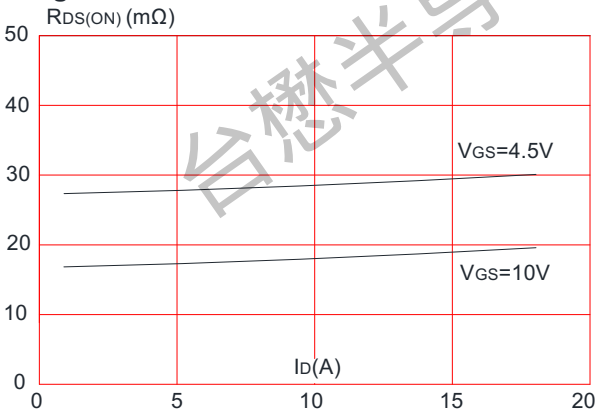

Figure 4: Body Diode Characteristics

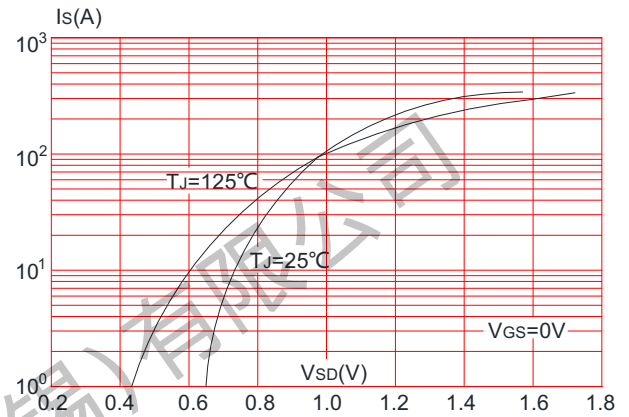

Figure 5: Gate Charge Characteristics

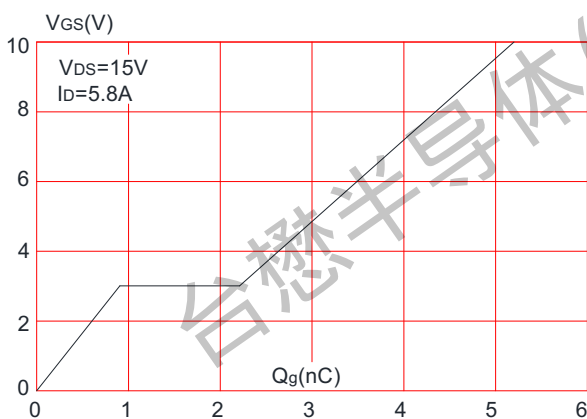
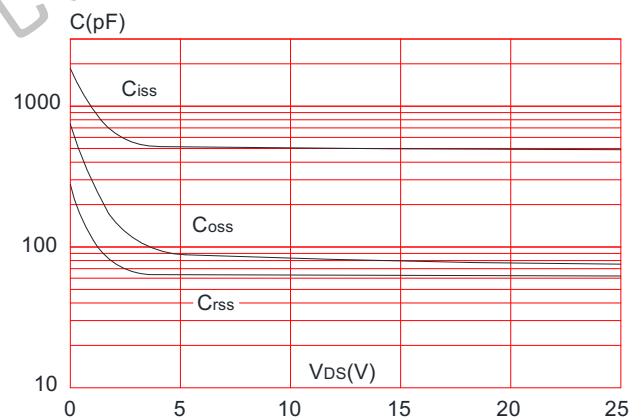

Figure 6: Capacitance Characteristics



TM06N03HMI

N-Channel Enhancement Mosfet

Figure 7: Normalized Breakdown Voltage vs. Junction Temperature

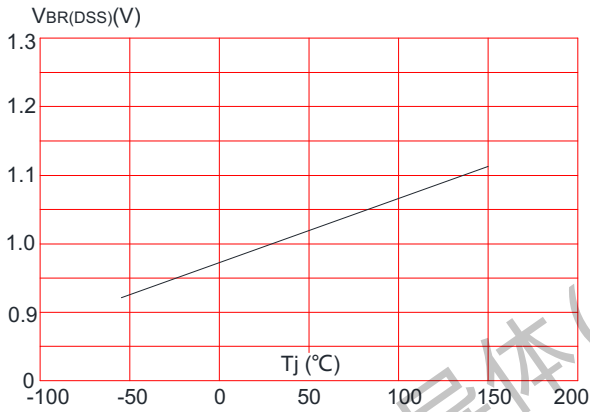

Figure 8: Normalized on Resistance vs. Junction Temperature

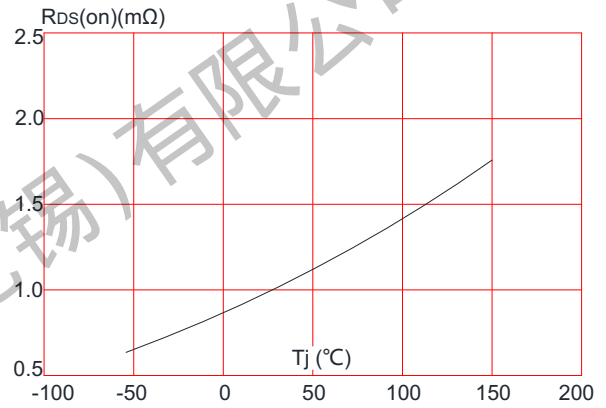

Figure 9: Maximum Safe Operating Area

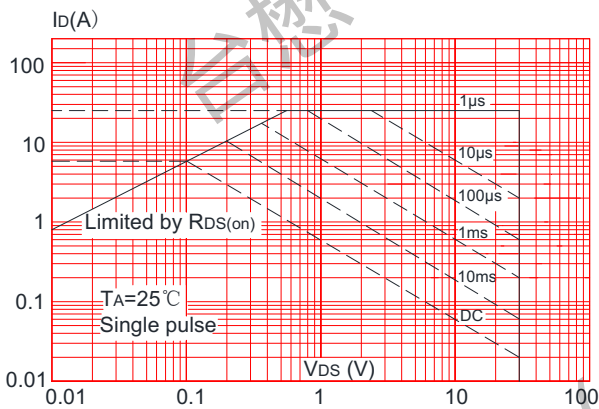

Figure 10: Maximum Continuous Drain Current vs. Ambient Temperature

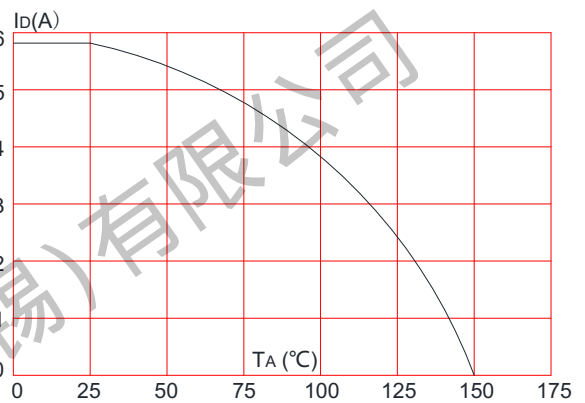
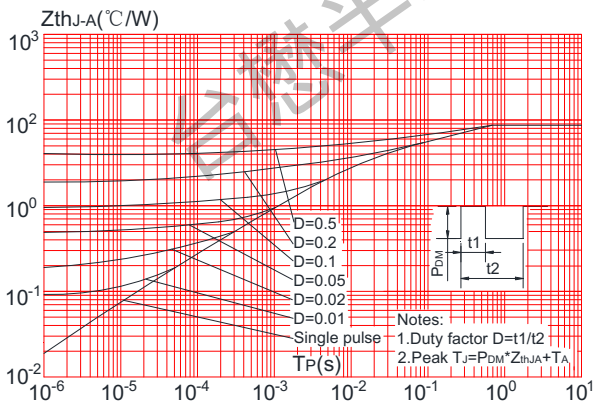

Figure.11: Maximum Effective Transient Thermal Impedance, Junction-to-Ambient





TM06N03HMI

N-Channel Enhancement Mosfet

Package Mechanical Data:SOT-23-3L

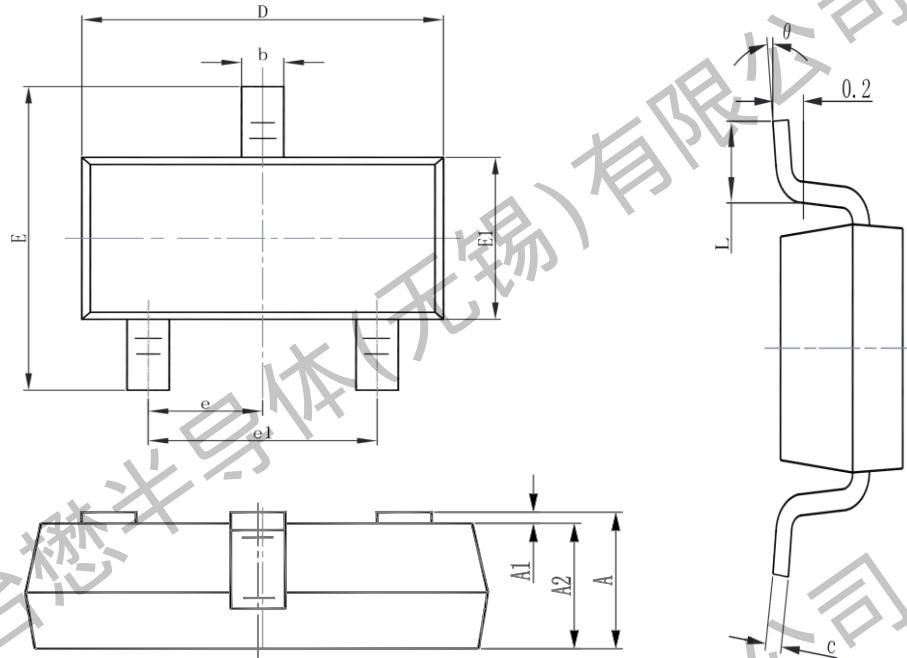

Symbol	Dimensions In Millimeters		Dimensions In Inches	
	Min.	Max.	Min.	Max.
A	1.050	1.250	0.041	0.049
A1	0.000	0.100	0.000	0.004
A2	1.050	1.150	0.041	0.045
b	0.300	0.500	0.012	0.020
c	0.100	0.200	0.004	0.008
D	2.820	3.020	0.111	0.119
E1	1.500	1.700	0.059	0.067
E	2.650	2.950	0.104	0.116
e	0.950(BSC)		0.037(BSC)	
e1	1.800	2.000	0.071	0.079
L	0.300	0.600	0.012	0.024
theta	0°	8°	0°	8°



TM06N03HMI

N-Channel Enhancement Mosfet

SOT-23-3L Packing

1. The method of packaging and dimension are shown as below figure. (Dimension in mm)

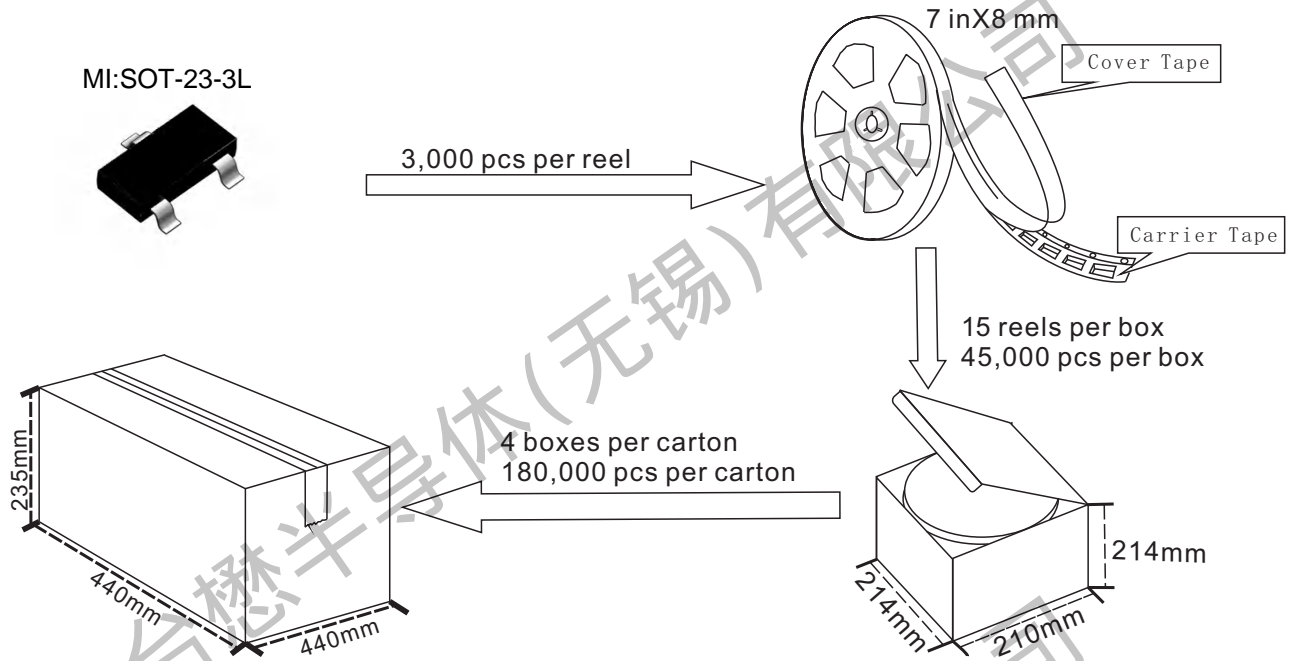

SOT-23-3L Embossed Carrier Tape

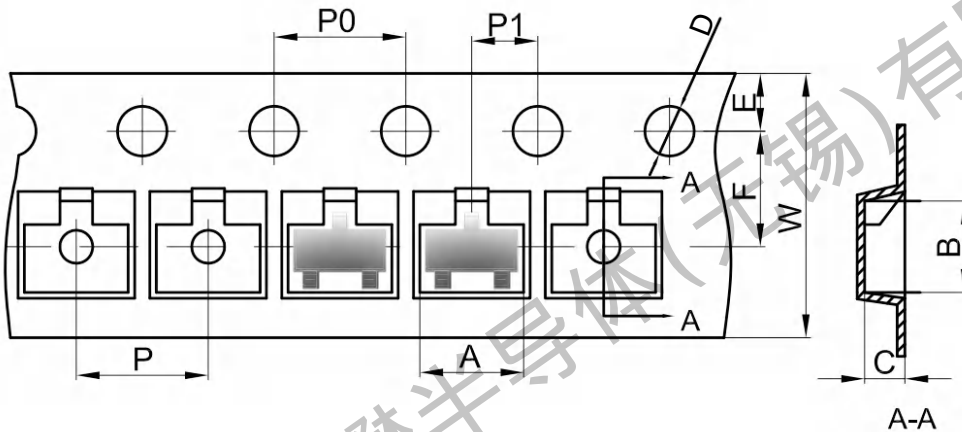

Dimensions are in millimeter

Pkg type	A	B	C	D	E	F	P0	P	P1	W
SOT-23-3L	3.15	2.77	1.22	Ø1.50	1.75	3.50	4.00	4.00	2.00	8.00

SOT-23-3L Tape Leader and Trailer

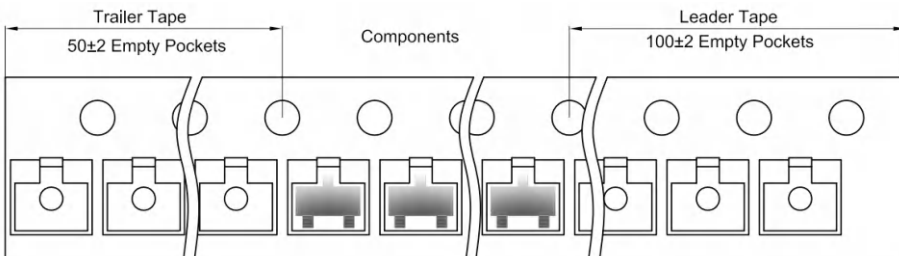



Important Notices and Disclaimers

- Tritech-MOS Technology Corp.reserves the right to change this document, its products, and specifications at any time without prior notice.
- Before final design, purchase, or use, customers should obtain and confirm the latest product information and specifications.
- Tritech-MOS Technology Corp. makes no warranties, representations or warranties regarding the suitability of its products for any specific purpose, and Tritech-MOS Technology Corp. does not assume any responsibility for application assistance or customer product design.
- Tritech-MOS Technology Corp. does not guarantee or assume any responsibility for the purchase or use of any unexpected or unauthorized products.
- Any intellectual property rights of Tritech-MOS Technology Corp. are not licensed through implicate or other means.
- Products of Tritech-MOS Technology Corp. are not included as critical components in life support equipment or systems without explicit written approval from Tritech-MOS Technology Corp.

Revision history:

Date	Rev	Description	Page
2023.09.06	23.09	Original	