



TM03N20SI

N-Channel Enhancement Mosfet

<p>General Description</p> <ul style="list-style-type: none"> • Low $R_{DS(ON)}$ • RoHS and Halogen-Free Compliant <p>Applications</p> <ul style="list-style-type: none"> • Load switch • PWM 	<p>General Features</p> <p>$V_{DS}=200V$ $I_D=3.0A$</p> <p>$R_{DS(ON)}=520m\Omega$(typ.) @$V_{GS}=10V$</p> <p>100% UIS Tested 100% R_g Tested</p> 
--	---

SI: SOT-89-3L

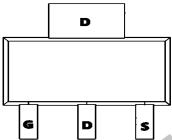
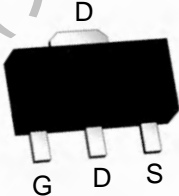
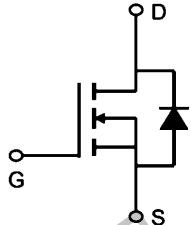
Marking: 03N20 OR ZK3

Absolute Maximum Ratings ($T_C = 25^\circ C$ Unless Otherwise Noted)

Symbol	Parameter	Rating	Units
V_{DS}	Drain-Source Voltage	200	V
V_{GS}	Gate-Source Voltage	± 20	V
$I_D@T_C=25^\circ C$	Continuous Drain Current, $V_{GS} @ 10V$	3	A
$I_D@T_C=100^\circ C$	Continuous Drain Current, $V_{GS} @ 10V$	1.8	A
I_{DM}	Pulsed Drain Current	11	A
P_D	Total Power Dissipation	3	W
T_{STG}	Storage Temperature Range	-55 to 175	$^\circ C$
T_J	Operating Junction Temperature Range	-55 to 175	$^\circ C$

Thermal Data

Symbol	Parameter	Typ.	Max.	Unit
$R_{\theta JA}$	Thermal Resistance Junction-ambient	---	62	$^\circ C/W$
$R_{\theta JC}$	Thermal Resistance Junction-Case	---	6.6	$^\circ C/W$



TM03N20SI

N-Channel Enhancement Mosfet

Electrical Characteristics: ($T_C=25^\circ\text{C}$ unless otherwise noted)

Symbol	Parameter	Conditions	Min	Typ	Max	Units
Off Characteristics						
BV_{DSS}	Drain-Source Breakdown Voltage	$V_{GS}=0V, I_D=250\ \mu A$	200	---	---	V
I_{DSS}	Zero Gate Voltage Drain Current	$V_{GS}=0V, V_{DS}=200V$	---	---	1	μA
I_{GSS}	Gate-Source Leakage Current	$V_{GS}=\pm 20V, V_{DS}=0A$	---	---	± 100	nA
On Characteristics						
$V_{GS(th)}$	GATE-Source Threshold Voltage	$V_{GS}=V_{DS}, I_D=250\ \mu A$	2	2.5	3	V
$R_{DS(on)}$	Drain-Source On Resistance	$V_{GS}=10V, I_D=2A$	---	520	580	$m\ \Omega$
Dynamic Characteristics						
C_{iss}	Input Capacitance ⁴	$V_{DS}=25V, V_{GS}=0V, f=1MHz$	---	579	---	pF
C_{oss}	Output Capacitance ⁴		---	89	---	
C_{rss}	Reverse Transfer Capacitance ⁴		---	2	---	
Switching Characteristics						
$t_{d(on)}$	Turn-On Delay Time ⁴	$V_{DS}=100V$ $R_{ENG}=2.5\ \Omega, V_{GS}=10V$	---	9	---	ns
t_r	Rise Time ⁴		---	11	---	ns
$t_{d(off)}$	Turn-Off Delay Time ⁴		---	14	---	ns
t_f	Fall Time ⁴		---	14	---	ns
Q_g	Total Gate Charge ⁴	$V_{GS}=10, V_{DS}=100V,$ $I_D=2A$	---	11	---	nc
Q_{gs}	Gate-Source Charge ⁴		---	2.4	---	nc
Q_{gd}	Gate-Drain "Miller" Charge ⁴		---	3.7	---	nc
Drain-Source Diode Characteristics						
I_S	Continuous Drain Current ²	$V_D=V_G=0V$	---	---	3	A
I_{SM}	Pulsed Drain Current		---	---	11	A
V_{SD}	Diode Forward Voltage ³	$V_{GS}=0V, I_{SD}=2A$	---	---	1.2	V

TM03N20SI

N-Channel Enhancement Mosfet

Typical Characteristics

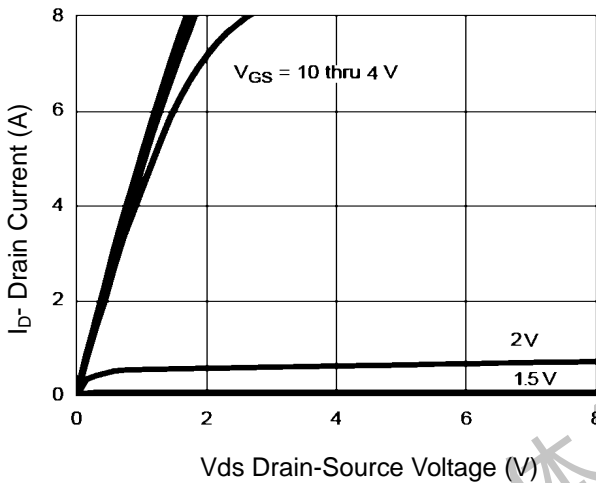

Figure 1 Output Characteristics

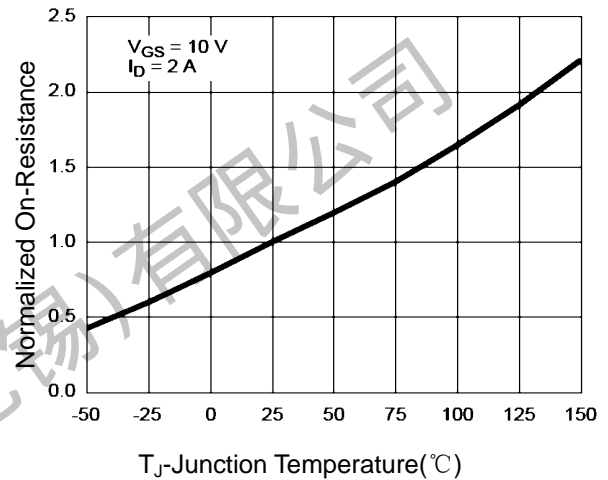

Figure 4 Rds(on)-Junction Temperature

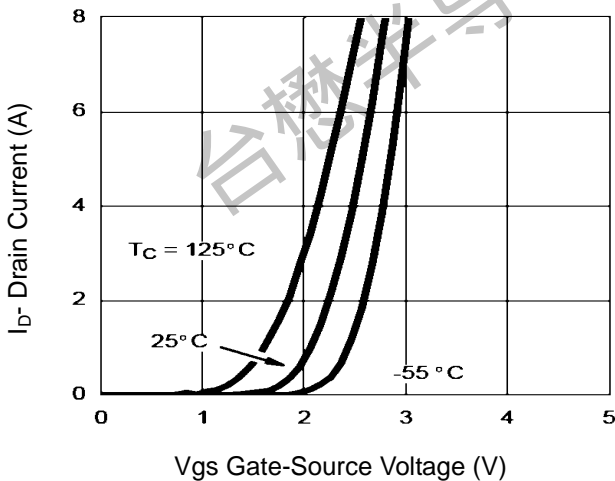

Figure 2 Transfer Characteristics

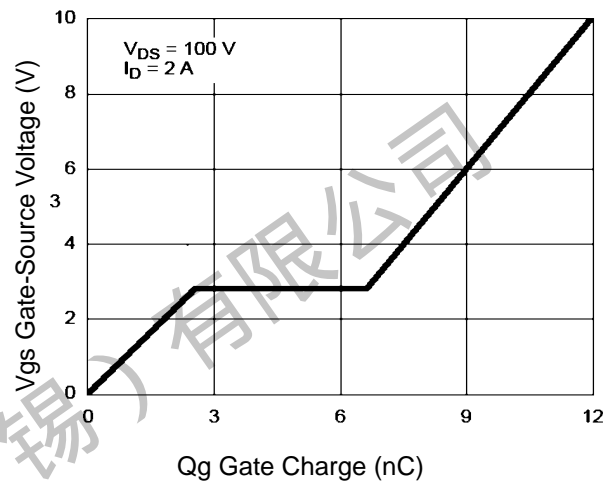

Figure 5 Gate Charge

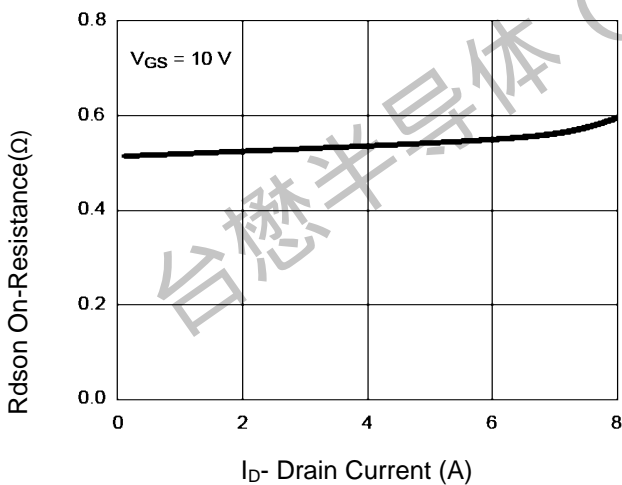

Figure 3 Rds(on)- Drain Current

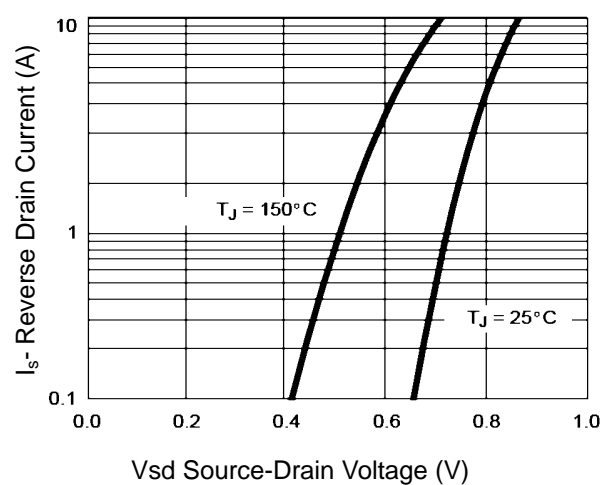

Figure 6 Source- Drain Diode Forward

TM03N20SI

N-Channel Enhancement Mosfet

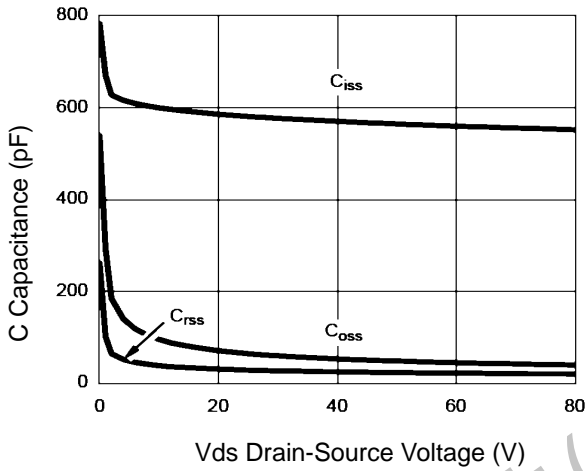

Figure 7 Capacitance vs Vds

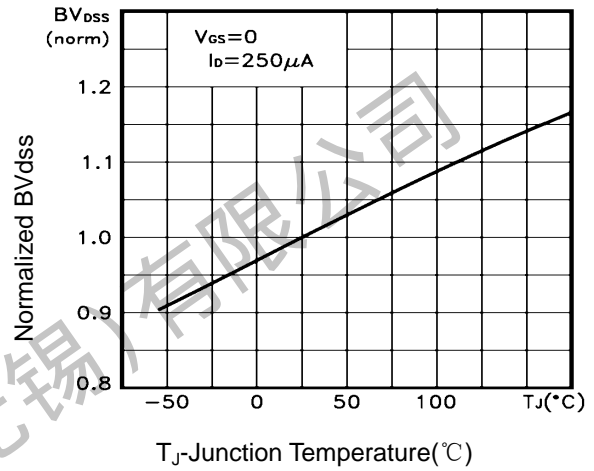

Figure 9 BV_{DSS} vs Junction Temperature

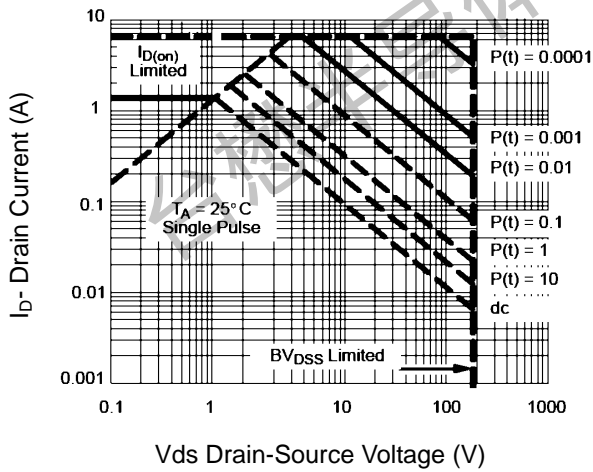

Figure 8 Safe Operation Area

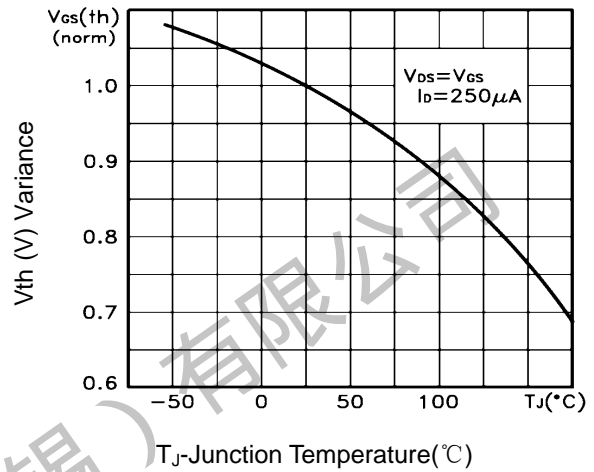

Figure 10 $V_{GS(th)}$ vs Junction Temperature

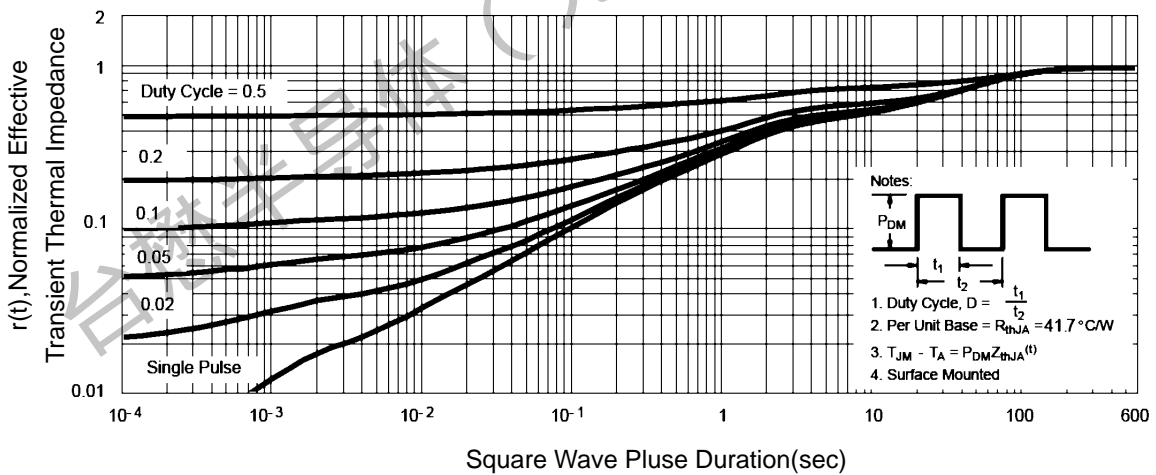

Figure 11 Normalized Maximum Transient Thermal Impedance



TM03N20SI

N-Channel Enhancement Mosfet

Package Mechanical Data:SOT-89-3L

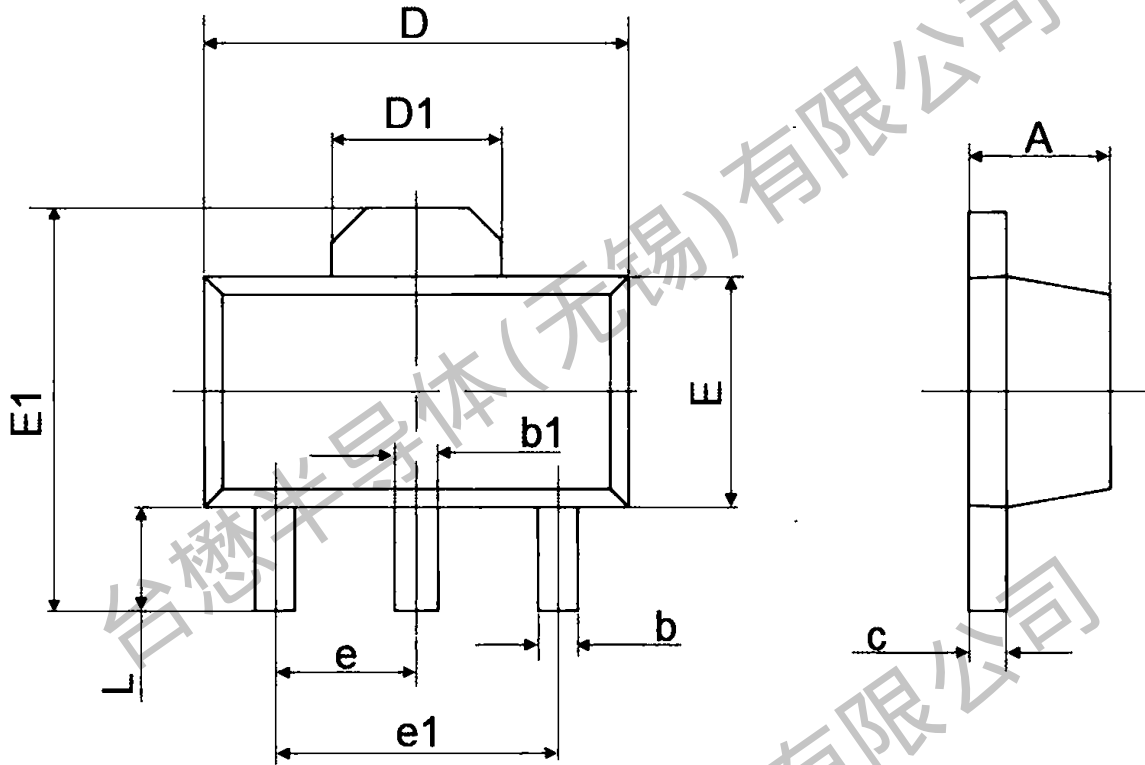

Symbol	Dimensions In Millimeters		Dimensions In Inches	
	Min	Max	Min	Max
A	1.400	1.600	0.055	0.063
b	0.320	0.520	0.013	0.020
b1	0.400	0.580	0.016	0.023
c	0.350	0.440	0.014	0.017
D	4.400	4.600	0.173	0.181
D1	1.550 REF.		0.061 REF.	
E	2.300	2.600	0.091	0.102
E1	3.940	4.250	0.155	0.167
e	1.500 TYP.		0.060 TYP.	
e1	3.000 TYP.		0.118 TYP.	
L	0.900	1.200	0.035	0.047

TM03N20SI

N-Channel Enhancement Mosfet

SOT-89-3L Embossed Carrier Tape

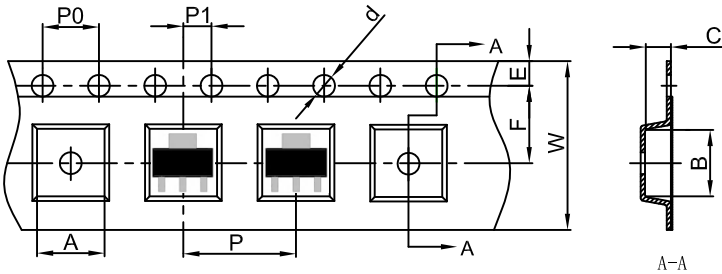

Packaging Description:
SOT-89-3L parts are shipped in tape. The carrier tape is made from a dissipative (carbon filled) polycarbonate resin. The cover tape is a multilayer film (Heat Activated Adhesive in nature) primarily composed of polyester film, adhesive layer, sealant, and anti-static sprayed agent. These reeled parts in standard option are shipped with 1,000 units per 7" or 18.0 cm diameter reel. The reels are clear in color and is made of polystyrene plastic (anti-static coated).
ALL DIM IN mm

Dimensions are in millimeter										
Pkg type	A	B	C	d	E	F	P0	P	P1	W
SOT-89-3L	4.85	4.45	1.85	Ø1.50	1.75	5.50	4.00	8.00	2.00	12.00

SOT-89-3L Tape Leader and Trailer

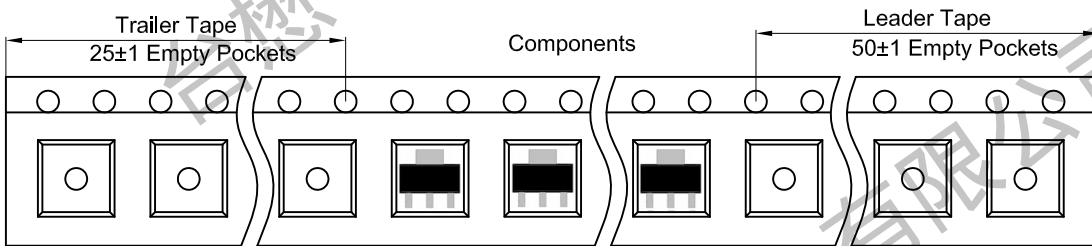

SOT-89-3L Reel

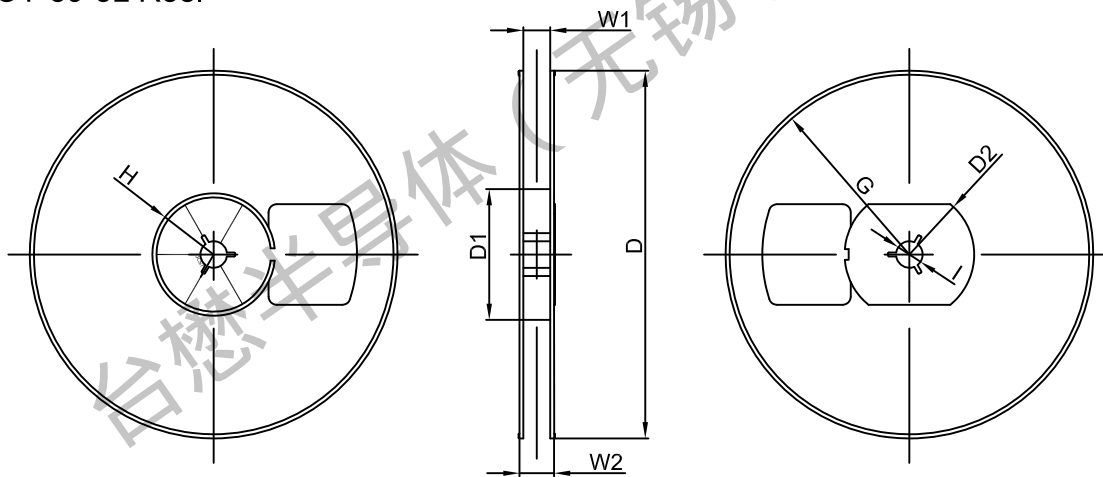

Dimensions are in millimeter								
Reel Option	D	D1	D2	G	H	I	W1	W2
7"Dia	Ø180.00	60.00	R32.00	R86.50	R30.00	Ø13.00	13.20	16.50

REEL	Reel Size	Box	Box Size(mm)	Carton	Carton Size(mm)	G.W.(kg)
1000 pcs	7 inch	10,000 pcs	205x195x220	40,000 pcs	430x415x240	



Important Notices and Disclaimers

- Tritech-MOS Technology Corp. reserves the right to change this document, its products, and specifications at any time without prior notice.
- Before final design, purchase, or use, customers should obtain and confirm the latest product information and specifications.
- Tritech-MOS Technology Corp. makes no warranties, representations or warranties regarding the suitability of its products for any specific purpose, and Tritech-MOS Technology Corp. does not assume any responsibility for application assistance or customer product design.
- Tritech-MOS Technology Corp. does not guarantee or assume any responsibility for the purchase or use of any unexpected or unauthorized products.
- Any intellectual property rights of Tritech-MOS Technology Corp. are not licensed through implicate or other means.
- Products of Tritech-MOS Technology Corp. are not included as critical components in life support equipment or systems without explicit written approval from Tritech-MOS Technology Corp.

Revision history:

Date	Rev	Description	Page
2023.10.19	23.10	Original	