



TM003N05I

N-Channel Enhancement Mosfet

<p>General Description</p> <ul style="list-style-type: none"> • Low $R_{DS(ON)}$ • RoHS and Halogen-Free Compliant <p>Applications</p> <ul style="list-style-type: none"> • Load switch • PWM 	<p>General Features</p> <p>$V_{DS} = 50V$ $I_D = 0.3A$</p> <p>$R_{DS(ON)} = 1100\ m\Omega$ (typ.) @ $V_{GS} = 10V$</p> <p>100% UIS Tested 100% R_g Tested</p> 
--	---

I: SOT-23

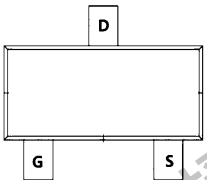
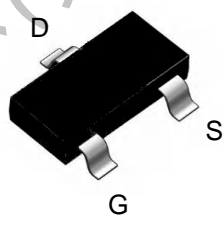
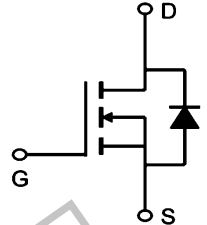
Marking: SS

Absolute Maximum Ratings ($T_C = 25^\circ C$ unless otherwise noted)

Symbol	Parameter	Rating	Units
V_{DS}	Drain-Source Voltage	50	V
V_{GS}	Gate-Source Voltage	± 20	V
$I_D @ T_A = 25^\circ C$	Continuous Drain Current, $V_{GS} @ 10V^1$	0.3	A
$I_D @ T_A = 70^\circ C$	Continuous Drain Current, $V_{GS} @ 10V^1$	0.18	A
I_{DM}	Pulsed Drain Current ²	1.5	A
$P_D @ T_A = 25^\circ C$	Total Power Dissipation ³	0.35	W
T_{STG}	Storage Temperature Range	-55 to 150	$^\circ C$
T_J	Operating Junction Temperature Range	-55 to 150	$^\circ C$

Thermal Data

Symbol	Parameter	Typ.	Max.	Unit
$R_{\theta JA}$	Thermal Resistance Junction-ambient ¹	---	162	$^\circ C/W$
$R_{\theta JC}$	Thermal Resistance Junction Case ¹	---	---	$^\circ C/W$

TM003N05I

N-Channel Enhancement Mosfet

Electrical Characteristics ($T_J=25\text{ }^\circ\text{C}$, unless otherwise noted)

Symbol	Parameter	Conditions	Min.	Typ.	Max.	Unit
BV_{DSS}	Drain-Source Breakdown Voltage	$V_{GS}=0V, I_D=250\mu A$	50	---	---	V
$R_{DS(ON)}$	Static Drain-Source On-Resistance ²	$V_{GS}=10V, I_D=0.3A$	---	1100	2500	m Ω
		$V_{GS}=4.5V, I_D=0.2A$	---	1200	3000	
$V_{GS(th)}$	Gate Threshold Voltage	$V_{GS}=V_{DS}, I_D=250\mu A$	0.8	1.2	1.6	V
I_{DSS}	Drain-Source Leakage Current	$V_{DS}=50V, V_{GS}=0V$	---	---	0.5	uA
		$V_{DS}=50V, V_{GS}=0V$	---	---	0.5	
I_{GSS}	Gate-Source Leakage Current	$V_{GS}=\pm 20V, V_{DS}=0V$	---	---	± 100	nA
Q_g	Total Gate Charge	$V_{DS}=25V, V_{GS}=10V, I_D=0.3A$	---	1.7	---	nC
Q_{gs}	Gate-Source Charge		---	0.47	---	
Q_{gd}	Gate-Drain Charge		---	0.25	---	
$T_{d(on)}$	Turn-On Delay Time	$V_{DS}=25V, V_{GS}=10V, R_G=6\Omega$ $I_D=0.3A$	---	2.6	---	ns
T_r	Rise Time		---	19	---	
$T_{d(off)}$	Turn-Off Delay Time		---	9.6	---	
T_f	Fall Time		---	49	---	
C_{iss}	Input Capacitance	$V_{DS}=25V, V_{GS}=0V, f=1MHz$	---	28.5	---	pF
C_{oss}	Output Capacitance		---	2.7	---	
C_{rss}	Reverse Transfer Capacitance		---	1.8	---	

Diode Characteristics

Symbol	Parameter	Conditions	Min.	Typ.	Max.	Unit
I_S	Continuous Source Current ^{1,4}	$V_G=V_D=0V$, Force Current	---	---	0.3	A
V_{SD}	Diode Forward Voltage ²	$V_{GS}=0V, I_{SD}=300mA$	---	---	1.2	V

Note :

- 1.The data tested by surface mounted on a 1 inch²FR-4 board with 2OZ copper.
- 2.The data tested by pulsed , pulse width $\leq 300\mu s$, duty cycle $\leq 2\%$
- 3.The power dissipation is limited by 150 $^\circ\text{C}$ junction temperature
- 4.The data is theoretically the same as I_D and I_{DM} , in real applications , should be limited by total power dissipation.

TM003N05I

N-Channel Enhancement Mosfet

Typical Characteristic Curve

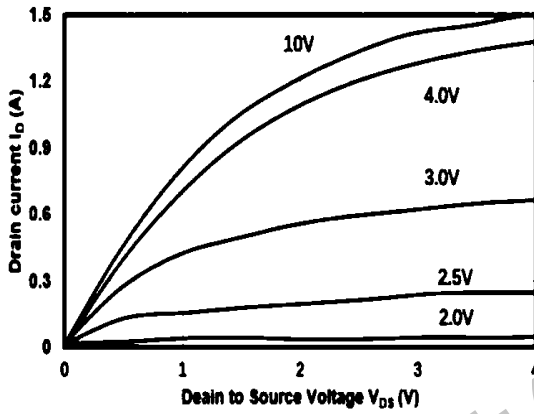

Figure 1: Output Characteristics

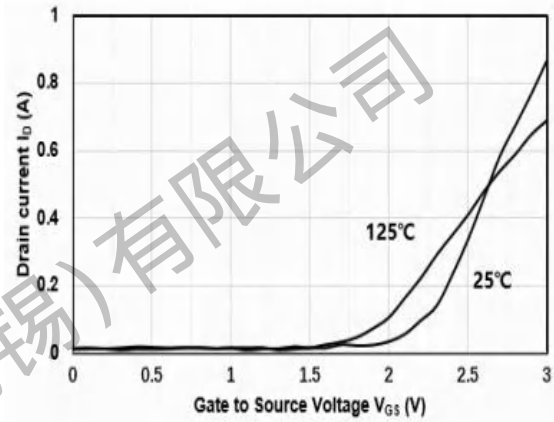

Figure 2: Transfer Characteristics

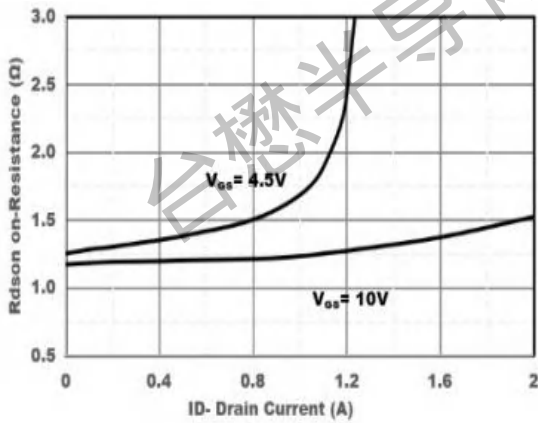

Figure 3: On-Resistance vs. Drain Current

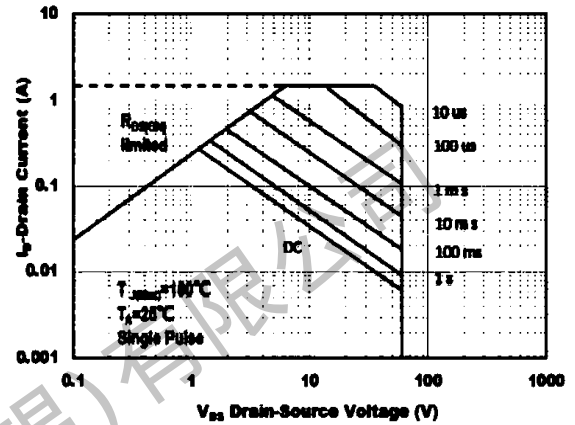

Figure 4: Safe Operating Area

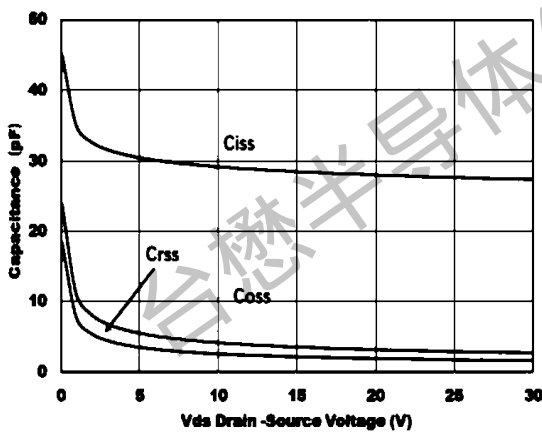

Figure 5: Capacitance Characteristics

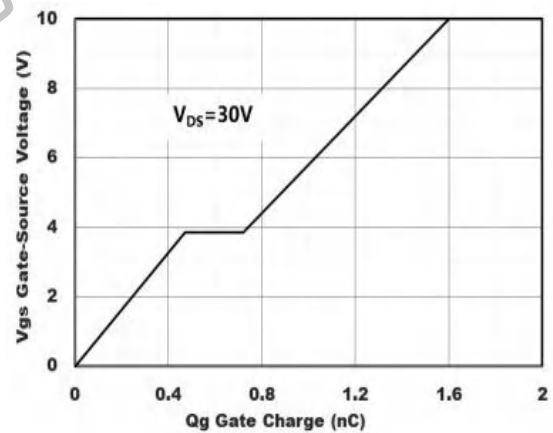

Figure 6: Gate-Charge Characteristics



TM003N05I

N-Channel Enhancement Mosfet

Package Mechanical Data:SOT-23

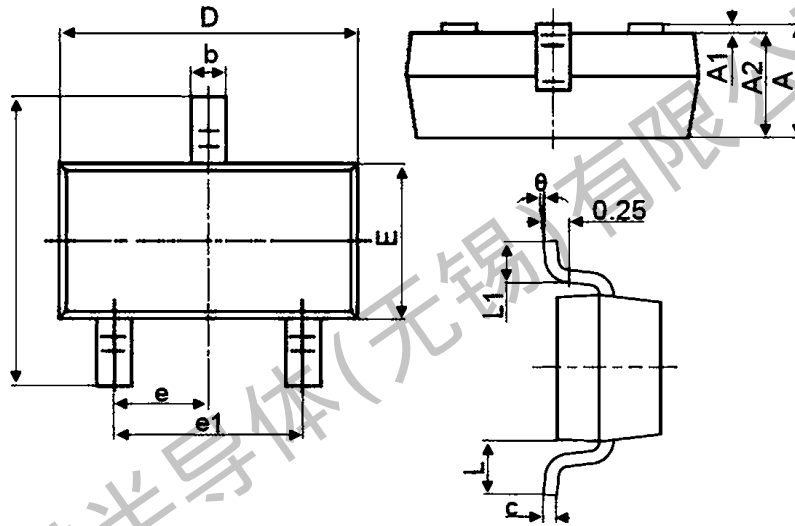

Symbol	Dimensions in Millimeters	
	MIN.	MAX.
A	0.900	1.150
A1	0.000	0.100
A2	0.900	1.050
b	0.300	0.500
c	0.080	0.150
D	2.800	3.000
E	1.200	1.400
E1	2.250	2.550
e	0.950TYP	
e1	1.800	2.000
L	0.550REF	
L1	0.300	0.500
θ	0°	8°



TM003N05I

N-Channel Enhancement Mosfet

SOT-23 Packing

1. The method of packaging and dimension are shown as below figure. (Dimension in mm)

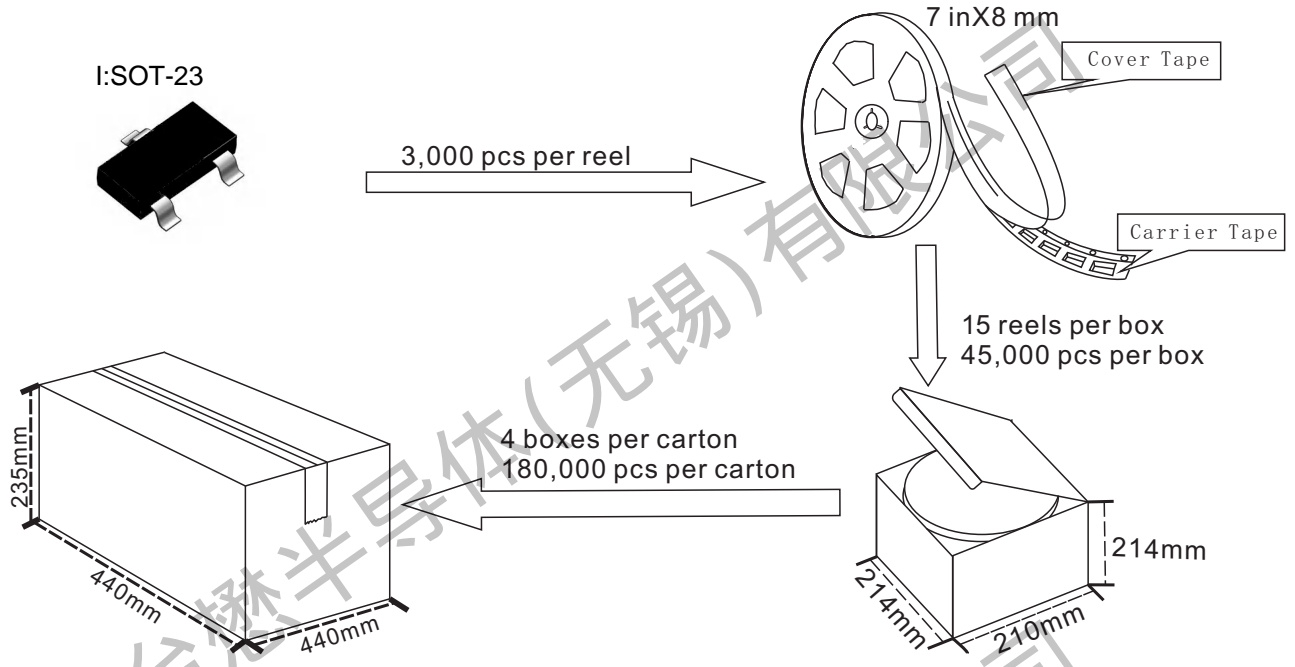

SOT-23 Embossed Carrier Tape

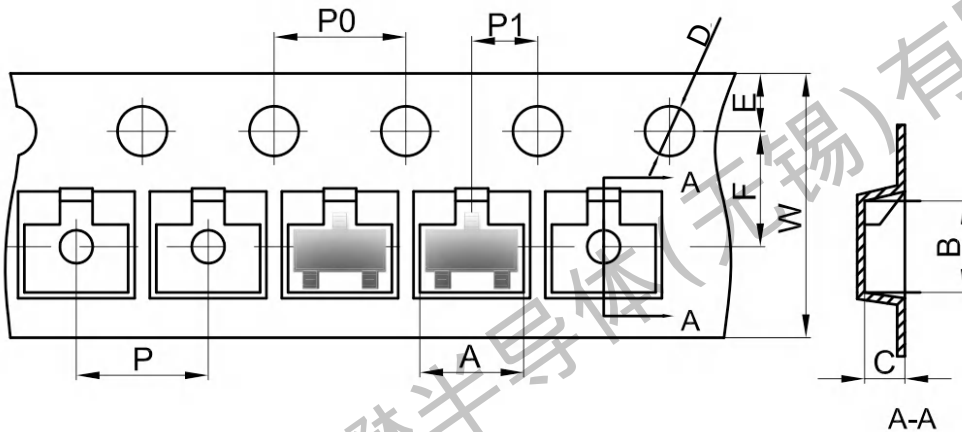

Dimensions are in millimeter

Pkg type	A	B	C	D	E	F	P0	P	P1	W
SOT-23	3.15	2.77	1.22	Ø1.50	1.75	3.50	4.00	4.00	2.00	8.00

SOT-23 Tape Leader and Trailer

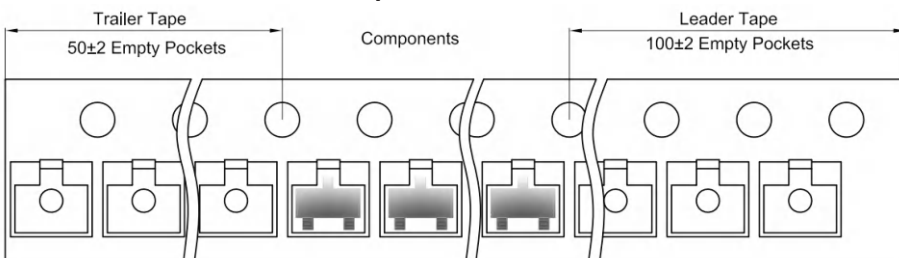



Important Notices and Disclaimers

- Tritech-MOS Technology Corp. reserves the right to change this document, its products, and specifications at any time without prior notice.
- Before final design, purchase, or use, customers should obtain and confirm the latest product information and specifications.
- Tritech-MOS Technology Corp. makes no warranties, representations or warranties regarding the suitability of its products for any specific purpose, and Tritech-MOS Technology Corp. does not assume any responsibility for application assistance or customer product design.
- Tritech-MOS Technology Corp. does not guarantee or assume any responsibility for the purchase or use of any unexpected or unauthorized products.
- Any intellectual property rights of Tritech-MOS Technology Corp. are not licensed through implicate or other means.
- Products of Tritech-MOS Technology Corp. are not included as critical components in life support equipment or systems without explicit written approval from Tritech-MOS Technology Corp.

Revision history:

Date	Rev	Description	Page
2023.06.29	23.06	Original	